

STOCK CATALOG

PEACHTREE CORNERS • MACON • AUGUSTA • SAVANNAH

OUR PARTNERS



INNOVATIVE AIR
TECHNOLOGIES

Redd-i



OUR PRODUCTS

Manufacturer	Description
Accurex	Engineered Restaurant Systems
Accutrol	Airflow Solutions for Critical Environments
Acme Engineering	Gas Detection Monitors: CO, CO ₂ , NO ₂ , Ammonia, VOC
Air Maid by Interzon	Advanced Ozone Generators for Industrial and Professional Use
AJ Manufacturing	Door Grilles, Stainless Steel Air Distribution
ATCO (Flex Air Division)	Flexible Duct
Broan	Bathroom Exhaust Fans
Carroll Manufacturing	Commercial Kitchen Exhaust Air Purification Systems
Commercial Acoustics	Sound Attenuators & Acoustical Fan Enclosures
Crown Products	Duct Take Off Fittings & Sheet Metal Accessories
Curbs Plus	Roof Curbs
DuroDyne	Sheet Metal Accessories
Flexmaster	Flexible Duct and Sheet Metal Accessories
Franklin Controls	Leading manufacturer of motor controls for HVAC, pump and industrial markets
Greenheck	Commercial Kitchen Hood Systems (UL Listed & Classified), Dampers & Louvers, Energy Recovery Units Ventilation Fans, Laboratory Fume Exhaust Fan Systems, Gas Fired And Electric Make-Up Air Units
Hamlin Sheet Metal	Spiral And Oval Duct; Single And Double Wall Construction
Innovative Air Technologies	Custom Low Dew Point Desiccant Units
Jeremias	NFPA 96 reduced or zero clearance grease duct for commercial kitchens
Kee's	Specialty Air Distribution Products
Mars	Air Doors; Fly Fans
Mojave	Liquid Dessicant Air Conditioners
Neptronic	Commercial/Industrial Humidification Systems & Electric Duct Heaters
Panasonic	Ceiling and Cabinet Exhaust Fans
Phoenix Air Systems	Hygienic Air Handlers
Precision Air Products	Ceiling Ventilation Systems for Operating Rooms
Prihoda	Fabric Duct Systems
Pro-R Duct	Exterior and Interior Insulated Ductwork Solutions for Engineers and Contractors
Q'mark	Electric Heat
Semco	Duct and Acoustical Products
Space Ray	Infrared Gas Heat
Thermal Corporation	Custom Air Handlers
Titus HVAC	Air Distribution, Security Grilles, Hospital Operating Room Systems, VAV And Fan Powered Terminal Units; Fan Coil Units, Underfloor Ventilation, Displacement Ventilation Systems & Chilled Beams
Tri-Dim	Air Filtration
Van-Packer Company	Kitchen Ventilation Products
Vent Products Inc.	Louvers, Dampers & Penthouses
Ventaire	Vehicle Exhaust Removal and Fume Extraction Systems
Vibro Acoustics	Noise Control Solutions
Vulcan	Electric, Steam & Hot Water Heating Equipment
Ward Industries	Access Doors For Round Duct
WeatherRite	Commercial and Industrial Makeup Air Units
Zoo Fans	De-stratification & Parking Garage Ventilation

CONTENTS



ACCESS DOORS	1
AIR DISTRIBUTION	6
DIFFUSERS	7
T-BAR SLOTS	12
LINEAR & PLENUMS	13
RETURNS	14
GRILLES	18
DOOR GRILLES	21
ACCESSORIES	22
DAMPERS	27
SPIRAL PIPE - SINGLE WALL	35
SPIRAL FITTINGS - SINGLE WALL	36
SNAPLOCK PIPE	40
SNAPLOCK PIPE ACCESSORIES	42
TAKEOFFS	44
FLEX DUCT	49
FLEXIBLE DUCT ACCESSORIES	51
TOOLS AND SUPPLIES	52
TERMINAL UNITS	54
TERMINAL UNIT ACCESSORIES	55
FANS	57
FAN ACCESSORIES	87
FAN ACCESSORIES	88
LOUVERS & BRICK VENTS	89
WALL CAPS	90
ROOF JACKS & ROOF CAPS	91
STORM CAP, COLLAR, ROOF FLASHING	92
PIPE BOXES & PIPE PORTALS	93
DRYER BOOSTER FANS & ACCESSORIES	94
ROOF CURBS	96
HEATERS	98
ELECTRIC HEATERS	98
GAS UNIT HEATERS	104
HEATER ACCESSORIES	105
CONTROL SYSTEMS	107
BAS SPECIFICATIONS	108
VIBRATION ISOLATION	114
TERMS AND CONDITIONS	118
OUR LOCATIONS	121

All purchases shall be subject exclusively to Holden & Associates' Terms and Conditions of Sale located at <https://www.holdenassoc.com/terms-and-conditions> or provided to you upon request. All reasonable efforts have been made to ensure the accuracy of the information contained in this document at the time of publication. Specifications, packaging and part numbers detailed within are subject to change. To verify or obtain the most up-to date information, please contact your outside sales representative.

Our Legacy

A HISTORY OF INNOVATION AND CREATING COMFORTABLE SPACES

Since 1946, Titus has focused on technologically advanced products that create the highest degree of comfort.

We've consistently led the industry by breaking the barriers of expectation and convention when it comes to technology. We've redefined how technology drives, influences and supports air management. And by being first to market with the most innovative approaches to air distribution, we're proud to say that the marketplace has taken notice, and is counting on us to lead the way into the next decade. A challenge we're more than happy to accommodate.

Titus has raised the bar on design, proving that functional can also be beautiful. And we've redefined what it means to be energy efficient, with a collection of smart technology products that optimize the use of natural resources.

Titus has also redefined what it means to work with an air management products partner. We pride ourselves on listening and responding so that we can not only meet expectations, but also exceed them. Service has been, and will always be, our main focus at Titus. And, it's why so many of our customers keep coming back.

[Welcome to your new comfort zone. It starts here.](#)



Redefine your comfort zone.™ | www.titus-hvac.com

 **Titus**
Redefine your comfort zone.™

MODEL AD



- For Round Duct
- Tested to 20" WG Positive & 10" W.G. Negative
- Galvanized construction
- Quick & Easy installation

Size					
6"	8"	10"	12"	14"	16"

MODEL CAD

ACCESS DOORS



- For rectangular / square duct
- Galvanized steel construction
- Frame 24 gauge 6×6 through 12×12 & 22 gauge larger than 12×12
- Door Panel 24 gauge
- 1" fiberglass insulation
- 1/2" wide dual gasket (compressible synthetic type)
- Door to frame and frame to duct
- Plated steel latches with galvanized steel strikes

		Width									
		6	8	10	12	14	16	18	20	22	24
Height	6	X									
	8		X								
	10			X							
	12				X						
	14					X					
	16						X				
	18							X			
	20								X		
	22										
	24										X

X = STOCKED SIZES

MODEL DW



- For drywall (mud flange)
- Galvanized construction
- 16 Gauge frame
- 16 Gauge door panel
- Concealed spring hinged allowing door to open 175°
- Easy opening screwdriver cam latch
- White powder coated steel

		Width						
		12	14	16	18	20	22	24
Height	12	X						
	14							
	16							
	18				X			
	20							
	22							
	24							X

X = STOCKED SIZES

MODEL F2

ACCESS DOORS



- Greased Duct Access Doors
- Galvanized steel construction
- Ceramic gasket permanently bonded to the outside panel to eliminate leakage.
- Temperatures up to 2,300 °F
- Zinc coated wing nuts easily turned by hand without tools

		Width				
		4	6	8	10	12
Height	8	X				
	10					
	12			X		
	14					
	16					X

X = STOCKED SIZES

MODEL MILCOR



- Access Doors for Drywall (exposed flange)
- Galvanized construction
- 16 Gauge frame
- 16 Gauge door panel
- Concealed spring hinge allowing door to open 175°
- Easy opening screwdriver latch
- White powder coated steel

ACCESS DOORS

		Width								
		8	10	12	14	16	18	20	22	24
Height	8	X								
	10		X							
	12			X						
	14									
	16					X				
	18						X			
	20									
	22									
	24									X

X = STOCKED SIZES

MODEL TMS & TMS-IB

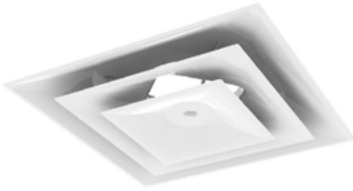

- Steel Square Cone Diffusers
- Steel construction
- For standard 15/16" lay-in ceilings
- 360° air pattern
- 3 cone construction
- Standard white finish
- Model IB includes an R-6 foil insulated back

AIR DISTRIBUTION

Neck	Face
6", 8"	12" × 12"
6", 8", 10", 12", 14", 15"	24" × 24"

ACTUAL FACE SIZE IS ¼" LESS

MODEL TMSA

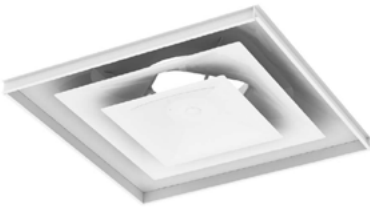

- Steel Square Cone Adjustable Diffusers
- Steel construction
- For standard 15/16" lay-in ceilings
- Adjustable discharge pattern between vertical & horizontal
- 3 cone construction
- Standard white finish

Neck	Face
6", 8"	12" × 12"
6", 8", 10", 12", 14", 15"	24" × 24"

ACTUAL FACE SIZE IS ¼" LESS

MODEL TMS-AA



- Aluminum Square Cone Diffusers
- Aluminum construction
- For standard 15/16" lay-in ceilings
- 360° air pattern
- 3 cone construction
- Standard white finish

Neck	Face
6", 8", 10", 12", 14"	24" × 24"

ACTUAL FACE SIZE IS ¼" LESS

MODEL TMQ



- Steel Square Cone Diffusers
- Steel construction
- For standard 15/16" lay-in ceilings
- 360° air pattern
- 4 cone construction
- Standard white finish

Neck	Face
6", 8", 10", 12", 14"	24" × 24"

ACTUAL FACE SIZE IS ¼" LESS

MODEL PSS

AIR DISTRIBUTION



- Steel Perforated Diffusers – Deflectors in Neck
- Steel construction
- For standard 15/16" lay-in ceilings
- Star pattern controller mounted in neck
- Perforated face has 3/16" holes on 1/4" centers
- Standard white finish

Neck	Face
6"	12" × 12"
6", 8", 10", 12", 14"	24" × 24"

ACTUAL FACE SIZE IS ¼" LESS

MODEL PAS



- Steel Perforated Diffusers – Defectors On Face
- Steel construction
- For standard 15/16" lay-in ceilings
- Face mounted pattern controllers
- Pattern controllers are adjustable to 1,2,3,4 way
- Perforated face has 3/16" holes on 1/4" centers
- Standard white finish

Neck	Face
6"	12" × 12"
6", 8", 10", 12", 14"	24" × 24"

ACTUAL FACE SIZE IS ¼" LESS

MODEL OMNI

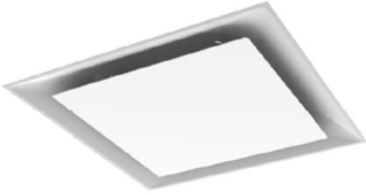

- Steel Plaque Diffusers
- Steel construction
- For standard 15/16" lay-in ceilings
- 360° air pattern
- 22 gauge steel panel
- Standard white finish

Neck	Face
6", 8"	12" × 12"
6", 8", 10", 12", 14", 15"	24" × 24"

ACTUAL FACE SIZE IS ¼" LESS

MODEL TMR



- Steel Round Cone Diffusers
- Steel construction
- 360° air pattern
- Two discharge settings (Max & higher induction)
- 3 cone construction
- For surface or direct mount to ductwork
- Standard white finish

Neck	Face
6"	11 1/8"
8"	14 3/4"
10"	18 1/4"
12"	22"
14"	26"
16"	29"

MODEL TDC

AIR DISTRIBUTION



- Steel Mitered Louvered Diffuser
- Steel construction
- For standard 15/16" lay-in ceilings
- Fixed mitered louvered face
- Removable core
- Standard white finish

Neck	Face
8" / 9" x 9"	12" x 12"
6" / 6" x 6"	24" x 24"
8" / 9" x 9"	24" x 24"
10" / 12" x 12"	24" x 24"
12" / 12" x 12"	24" x 24"
14" / 15" x 15"	24" x 24"
18" x 18" *	24" x 24"

ACTUAL FACE SIZE IS ¼" LESS

*SQ TO ROUND ADAPTERS AVAILABLE

MODEL TDC

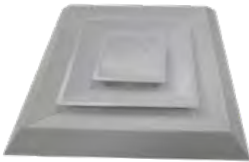

- Steel Mitered Louvered Diffuser
- Steel construction
- Beveled edge for surface mounting (Frame 6)
- Fixed mitered louvered face
- Removable core
- Standard white finish

Neck	Face
6" x 6" *	11" x 11"
9" x 9" *	14" x 14"
12" x 12" *	17" x 17"
15" x 15" *	20" x 20"
18" x 18" *	23" x 23"

*SQ TO ROUND ADAPTERS AVAILABLE

MODEL TDC-AA



- Aluminum Mitered Louvered Diffuser
- Aluminum construction
- For standard 15/16" lay-in ceilings
- Fixed mitered louvered face
- Removable core
- Standard white finish

Neck	Face
6" / 6" × 6"	24" × 24"
8" / 9" × 9"	24" × 24"
10" / 12" × 12"	24" × 24"
12" / 12" × 12"	24" × 24"
14" / 15" × 15"	24" × 24"
18" × 18" *	24" × 24"

ACTUAL FACE SIZE IS ¼" LESS

*SQ TO ROUND ADAPTERS AVAILABLE

MODEL T3SQ

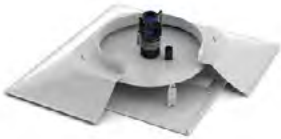

- Steel Plaque Thermal Diffusers
- Steel construction
- For standard 15/16" lay-in ceilings
- Heatcool changeover stand alone diffuser
- Plaque face
- Standard white finish

Neck	Face
6", 8", 10", 12"	24" × 24"

ACTUAL FACE SIZE IS ¼" LESS

T-BAR SLOTS



MODEL TBAR



AIR DISTRIBUTION

- Steel T-bar Slot Diffuser
- Steel construction
- For standard 15/16" lay-in ceilings
- 180° air pattern controller
- Fiberglass insulation (end caps are not insulated)
- 8" high
- Standard black edges on single slot
- Standard black edges and white center tee on two slot

Neck	Description
8"	24" Long – 1 Slot @ 1"
8"	24" Long – 2 Slots @ 1"
8", 10"	48" Long – 2 Slots @ 1"
6", 8"	24" Long – 1 Slot @ 1-½"
8"	24" Long – 2 Slots @ 1-½"
6", 8", 10", 12"	48" Long – 1 Slot @ 1-½"
6", 8", 10", 12"	48" Long – 2 Slots @ 1-½"

ACTUAL FACE SIZE IS ¼" LESS

MODEL PATCH PLATES



- Galvanized construction
- 16 × 8 plate for swapping collar size on plenums or tbar slots
- Oval inlets on 8", 10", 12"

Size			
6"	8"	10"	12"

MODEL ML



- Aluminum construction
- For surface mount applications
- 180° "ice-tong" pattern controllers
- Concealed hanger bracket frame "2A"
- Endcaps
- Standard white finish with black pattern controllers

Length	Description	Neck Width	Face Width
24"	1 Slot @ 1"	2 ½"	3 ¼"
48"	1 Slot @ 1"	2 ½"	3 ¼"
24"	2 Slots @ 1"	4 ¼"	5"
48"	2 Slots @ 1"	4 ¼"	5"

FACE LENGTH IS ¼" MORE ENDCAP TO ENDCAP

MODEL PLENUM



- Steel Insulated Plenums for ML Slot
- Steel construction
- Hemmed edge, frame "2A" for concealed mounting
- Fiberglass insulation
- Available with face operable damper in inlet (please specify)

Neck	Description	Width
6"	24" Long - 1 Slot @ 1"	2 11/16"
8"	48" Long - 1 Slot @ 1"	2 11/16"
8"	24" Long - 2 Slots @ 1"	4 7/16"
8", 10"	48" Long - 2 Slots @ 1"	4 7/16"

ACTUAL FACE SIZE IS ¼" LESS

MLAP ALIGNMENT PIN

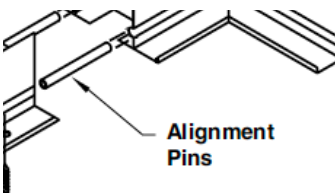

END BORDERS



MODEL 45F

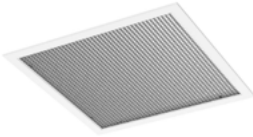

- Aluminum Eggcrate Sightproof Returns
- Aluminum construction
- For standard 15/16" lay-in ceilings
- Square neck
- 1/2"×1/2"×1/2" sightproof 45° core with frame
- Standard white finish

Neck	Face
22" × 10"	24" × 12"
22" × 22"	24" × 24"

ACTUAL FACE SIZE IS ¼" LESS

AIR DISTRIBUTION

MODEL 50F

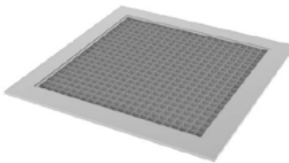

- Aluminum Eggcrate Returns
- Aluminum construction
- For standard 15/16" lay-in ceilings
- Square neck
- 1/2"×1/2"×1/2" core with frame
- Standard white finish

Neck	Face
10" × 10"	12" × 12"
22" × 10"	24" × 12"
22" × 22"	24" × 24"
46" × 22"	48" × 24"

ACTUAL FACE SIZE IS ¼" LESS

RETURNS



MODEL 50F

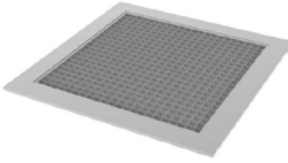

- Aluminum Eggcrate Returns
- Aluminum construction
- For surface mount
- Square neck
- 1/2"×1/2"×1/2" core with frame & screwholes
- Standard white finish

AIR DISTRIBUTION

		Width									
		6	8	10	12	14	16	18	20	22	24
Height	6	X									
	8		X								
	10			X						X	
	12				X						X
	14					X					
	16						X				
	18							X			
	20										
	22										
	24										X

FACE SIZE IS +1 3/4"

X = STOCKED SIZES

MODEL PAR

AIR DISTRIBUTION

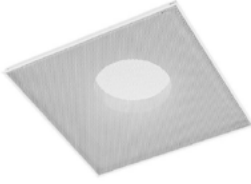

- Steel Perforated Returns
- Steel construction
- For standard 15/16" lay-in ceilings
- Round inlet
- No pattern controllers
- Perforated face has 3/16" holes on 1/4" centers
- Standard white finish

Neck	Face
6"	12" × 12"
6", 8", 10", 12", 14", 16"	24" × 24"

ACTUAL FACE SIZE IS ¼" LESS

MODEL PAR

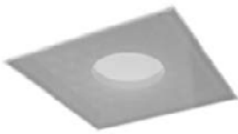

- Steel Perforated Returns
- Steel construction
- For standard 15/16" lay-in ceilings
- Square neck
- No pattern controllers
- Perforated face has 3/16" holes on 1/4" centers
- Standard white finish

Neck	Face
10" × 10"	12" × 12"
22" × 10"	24" × 12"
22" × 22"	24" × 24"

ACTUAL FACE SIZE IS ¼" LESS

MODEL 50FF



- Aluminum Eggcrate Filter Grille
- Aluminum construction
- For standard 15/16" lay-in ceilings
- 20"×20" Square neck
- 1/2"×1/2"×1/2" core with hinged frame
- Standard white finish

Neck	Face
20" × 20"	24" × 24"

ACTUAL FACE SIZE IS ¼" LESS

MODEL 350RLF1



- Steel Louvered Filter Return Grille
- Steel construction
- For standard 15/16" lay-in ceilings
- 3/4" blade spacing
- 35° fixed deflection
- Flange with hinged frame
- Standard white finish

Neck	Face
20" × 20"	24" × 24"

ACTUAL FACE SIZE IS ¼" LESS

MODEL USVH3



AIR DISTRIBUTION

- Aluminum Spiral Mount Grilles
- Extruded aluminum construction
- Surface mount
- Double deflection
- Front blades parallel to short dimension
- Flange frame with screwholes
- Adjustable scoop to direct airflow
- Standard white finish

Neck	Face
10" × 6"	13 ¼" × 7 ¼"
14" × 6"	17 ¼" × 7 ¼"
18" × 6"	21 ¼" × 7 ¼"
24" × 6"	27 ¼" × 7 ¼"

MODEL 350RL



- Steel Louvered Return Grilles
- Steel construction
- For surface mount
- 3/4" blade spacing
- 35° fixed deflection
- Blades parallel to long dimension
- Flange frame with screwholes
- Standard white finish

AIR DISTRIBUTION

		Width																							
		4	6	8	10	12	14	16	18	20	22	24	26	28	30	32	34	36	38	40	42	44	46	48	
Height	4			X																					
	6		X	X	X	X	X	X	X			X													
	8			X	X	X	X	X	X			X													
	10				X	X	X	X	X		X	X													
	12					X	X	X	X			X			X			X							
	14						X	X	X			X													
	16							X	X			X													
	18								X			X						X							
	20									X															
	22										X														
	24											X						X						X	
	26																								

FACE IS LISTED SIZE +1 3/4"

X = STOCKED SIZES

MODEL 300RS

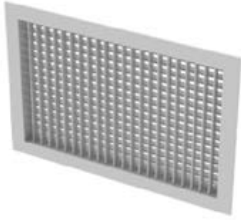

AIR DISTRIBUTION

- Steel Double Deflection Supply Registers
- Steel construction
- Surface mount
- Double deflection
- Front blades parallel to short dimension
- Flange frame with screwholes
- Opposed blade damper
- Standard white finish

		Width										
		4	6	8	10	12	14	16	18	20	22	24
Height	4			X	X	X	X					
	6		X	X	X	X	X	X	X			X
	8			X	X	X	X	X	X			X
	10				X	X	X	X	X			X
	12					X	X	X	X			X
	14						X	X	X	X		X
	16							X	X			

FACE IS LISTED SIZE +1 3/4"

X = STOCKED SIZES

DOOR GRILLES



MODEL DGDF



- Aluminum door grilles
- Extruded aluminum construction
- For surface mount
- Expandable frame for 1" to 1-3/4" doors
- Blades on .666" centers
- Double flange frame with screwholes
- Standard white finish

AIR DISTRIBUTION

		Width										
		4	6	8	10	12	14	16	18	20	22	24
Height	12					X			X			X
	14											
	16							X				
	18								X			
	20											
	22											
	24											X

FACE IS LISTED SIZE +1 3/4"

X = STOCKED SIZES

MODEL TRM

AIR DISTRIBUTION



- Plaster Frames for Diffusers
- Aluminum construction
- Rapid mount frame for t-bar diffusers to be surface mounted
- Standard white finish

		Width			
		12	24	36	48
Height	12	X			
	24	X	X		
	36				
	48		X		

RECOMMENDED CEILING OPENING IS 1/2" GREATER

X = STOCKED SIZES

MODEL TBF



Plaster Frames for T-bar Slots

Sizes	
24" × 2"	For 1" wide (1) slot T-bar slot
24" × 2.5"	For 1.5" wide (1) slot T-bar slot
24" × 4"	For 1" wide (2) slot T-bar slot
24" × 5"	For 1.5" wide (2) slot T-bar slot
48" × 2"	For 1" wide (1) slot T-bar slot
48" × 2.5"	For 1.5" wide (1) slot T-bar slot
48" × 4"	For 1" wide (2) slot T-bar slot
48" × 5"	For 1.5" wide (2) slot T-bar slot

RECOMMENDED CEILING OPENING IS 3/4" GREATER

MODEL PERF

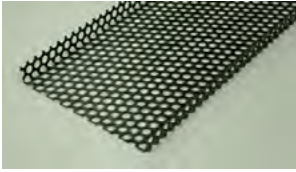

- Black Perforated Metal
- Steel construction
- For standard 15/16" lay-in ceilings
- 22 gauge with 51% free area
- 48" length
- Standard black finish

Size
4' × 4" Wide – 1 Side Flange Up
4' × 5" Wide – 1 Side Flange Up

MODEL INS BACKPAN



- Insulated Back for Lay-in Diffusers
- R6 insulated blanket
- Loose for field installation

Size
24" × 24"

MODEL RETURN CANOPY



- Galvanized 20 gauge steel construction with ¼" fiberglass liner
- Reduces cross-talk noise in common plenum spaces
- Serves as a light shield above grille

Size
24" × 12"
24" × 24"

MODEL LFC



- Light Clips for 9/16" Flat Tee Ceilings
- Light clip
- Used when you have 9/16" standard narrow tee grids
- Allows a standard lay-in diffuser for 15/16" to be used
- Qty (4) needed for each

AIR DISTRIBUTION

MODEL T-SB



- Sectorizing Baffle
- Steel construction
- Furnished in multiples of 90° to fit round neck
- Used to baffle on or more quadrants of the diffuser
- Standard black finish

Size					
6"	8"	10"	12"	14"	15"

TOUCH UP T-PAINT



- Touch up paint for air distribution

Color		
White #26	Silver #01	Black #84

AIR DISTRIBUTION

MODEL FB

- Fiberglass Boxes
- R6 ductboard box
- No collar

Size
24" × 12"
24" × 24"

MODEL SQ-TO-RD



- Steel Square to Rounds
- Galvanized steel
- 3" base
- 2-1/2" collar
- Uninsulated
- Black interior backpan

Size	Collar
6" × 6"	4", 6"
8" × 8"	6", 8"
9" × 9"	6", 8"
10" × 10"	6", 8", 10", blank pan
12" × 12"	6", 8", 10", 12"
14" × 14"	8", 10", 12", 14"
15" × 15"	12", 14"
16" × 16"	12", 14", 16"
18" × 18"	6", 8", 10", 12", 14", 16", 18"
20" × 20"	6", 8", 10", 12", 14", 16", 18", 20", blank pan
22" × 10"	6", 8", 10"
22" × 22"	6", 8", 10", 12", 14", 16", 18", 20", blank pan

MODEL D-75



- Radial Opposed Blade Damper
- Steel construction
- Mounts directly to the diffuser neck
- 3 sets of gang operated opposed blades
- Standard mill finish

Size			
6"	8"	10"	12"

MODEL AG-75



- Radial Opposed Blade Damper

Size
16"

MODEL D-100



- Sliding Blade Damper
- Steel construction
- Mounts directly to the diffuser neck
- Gang operated radial sliding blades
- Standard mill finish

Size				
6"	8"	10"	12"	14"

MODEL AG-85



- Radial Opposed Blade Damper

Size
15"

MODEL AG-15-K



- Opposed Blade Dampers
- Steel construction
- Neck mounted damper for sidewall grilles
- Mill finish

AIR DISTRIBUTION

		Width									
		6	8	10	12	14	16	18	20	22	24
Height	6	X									
	8		X								
	10			X							
	12				X						
	14					X					
	16						X				
	18							X			
	20								X		
	22									X	
	24										X

X = STOCKED SIZES

DAMPERS

MODEL WD-330



- Gravity Dampers
- Galvanized steel frame (18ga) with aluminum blades
- Vinyl blade seals
- 2500fpm velocity
- 2.0 W.G. pressure
- Vertical mount (horizontal airflow)

Size
12" × 12"
18" × 18"
24" × 24"

MODEL WD-100



- Galvanized steel frame (18ga) with aluminum blades
- Vinyl blade seals
- 2500fpm velocity
- 1.0 W.G. pressure
- Horizontal mount (vertical airflow)

Size
8" × 8"
10" × 10"
12" × 12"
16" × 16"
18" × 18"
24" × 24"

MODEL CRD



- Ceiling Radiation Dampers
- Galvanized steel frame & blades
- 165° fusible link
- UL555C fire resistance for 3hrs or less when installed with a thermal blanket

Sizes

6", 8", 10", 12", 14"

MODEL CRD-2-24

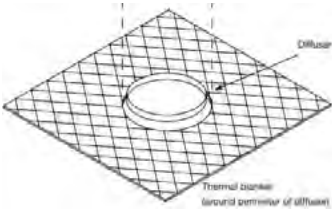

- Quilted thermal blanket accessory
- 2300° temperature limit
- 0.10" thick
- Gray color

Sizes

24" × 24"

MODEL 175-X

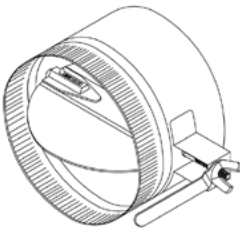

- Round Damper Sleeve
- Galvanized steel
- Continuous weld seam
- 2" W.G static pressure
- 2" damper handle standoff
- Manual volume damper with 1/4" continuous rod damper axis with locking regulator & grommets at the collar penetrations

Sizes

4", 5", 6", 7", 8", 10", 12", 14", 16", 18", 20"

MODEL VCD-23



- Galvanized construction
- Pressure up to 5in W.G.
- Leakage class 1A @ 1in W.G.
- Blade and jamb seals
- 120v two position actuator

Size
12" × 12"
24" × 24"

MODEL AA



- Galvanized construction
- Normally closed with end switch rated for 10 amp load
- C-UL-US rated
- 24v or 120v 2 position actuator available

Size
4" (24v only)
6"
8"
10"
12"
14"

MODEL DD-GXCOD



- Galvanized construction
- Gear driven remote cable operated damper
- 10ft attached cable
- Hex head for 1/4" standard nut driver or medium flat screw driver

Options
Assembled damper w/10ft cable 6",8",10",12", 14"

AIR DISTRIBUTION

MODEL DD-GCOD



- Concealed ceiling control box
- Used in lieu of plenum/diffuser mount of cable damper operator

MODEL DD-CODG



- Loose gear cable kit for existing dampers
- 10ft length
- Hex head for 1/4" standard nut driver or medium flat screw driver
- Fits 3/8" shaft or 1/4" shaft

MODEL FD-150X12



- Fire Dampers
- Galvanized steel
- 165° fusible link
- UL555 rated for 1-1/2" hour
- For use in walls or floor
- 12" long 22 gauge sleeve
- (2) loose angles, 1.5"

AIR DISTRIBUTION

STATIC RATED, CR TYPE, ROUND, HORIZONTAL OR VERTICAL MOUNT

Sizes						
6"	8"	10"	12"	14"	16"	18"

STATIC RATED, A TYPE, HORIZONTAL OR VERTICAL MOUNT

Sizes			
12" x 12"	24" x 12"	24" x 24"	36" x 12"

STATIC RATED, B TYPE, HORIZONTAL OR VERTICAL MOUNT

Sizes				
6" x 6"	8" x 6"	8" x 8"	10" x 8"	10" x 10"
12" x 8"	12" x 10"	12" x 12"	14" x 8"	14" x 10"
14" x 12"	14" x 14"	16" x 10"	16" x 12"	16" x 16"
18" x 12"	18" x 14"	18" x 18"	24" x 12"	24" x 24"

REPLACEMENT FIRE DAMPER LINKS



Options	
165°F	212°F



Award-Winning, Innovative Airflow Solutions for Critical Environments

About Accutrol



Headquartered in Danbury, Connecticut, Accutrol designs and manufactures pioneering HVAC solutions for healthcare and laboratory settings from operating suites to compounding pharmacies and BSL-4 labs.

Accutrol's product line features the patented, award-winning ultra low pressure drop AccuValve® portfolio, air flow measurement tools, touchscreen room and fume hood monitors, sensors and more all designed to deliver true airflow measurement readings with rapid responses to changing conditions, helping to ensure safe and protective environment.

Accutrol's solutions are BACnet® native, third-party compatible, and NIST-traceable. The AccuValve® is available in a range of sizes and options, and factory-shipped settings are stored indefinitely by Accutrol. The intuitive touchscreen monitors display real-time data, and occupants are immediately alerted with visual and audible alarms if conditions move outside of set parameters.

The Insight software allows facility managers to make changes in the field without the need to schedule and pay for maintenance from the manufacturer. Accutrol's product quality and reliability is trusted by the top facilities around the world to deliver safety and compliance, energy efficiency, and ease-of-use.



AccuValve® Airflow Control Valves



Insight Companion Software



IsoTek® Room Monitor



FHM3 Fume Hood Monitor



Accurate Readings for Safer Spaces

True airflow measurement with no-drift sensors and no required calibration provides reliable air flow control.



Award-Winning Software

Use the Insight software to set up, manage, and troubleshoot your critical spaces. Effortlessly analyze trends and generate reports for accrediting agencies.



Energy and Cost Savings

The industry-leading AccuValve® technology is inherently energy-efficient, providing cost savings and extending the life of the facility HVAC system.



Easy Installation and Commissioning

Valves can be mounted in any position, with no straight duct runs required. Optional USB or Bluetooth® connection makes commissioning quick and easy.



Dependable Localized Supply Chain

Practicing Lean Manufacturing, Accutrol is ISO 9000:2015 certified, with a local supply chain and 35,000 square foot manufacturing footprint that can quickly scale up production to deliver on time.



True Owner Independence

Improve building efficiency and reduce downtime for increased ROI. The five year product warranty and no proprietary software required for maintenance provides owners with peace of mind.

SPIRAL PIPE - SINGLE WALL



SPIRAL PIPE

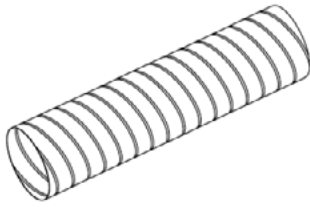

- Spiral Ductwork
- Galvanized steel per ASTM A653
- Slip-fit connections
- 10' joints
- 10" positive W.G.

Size			
6"	8"	10"	12"
14"	16"	18"	20"

SPRIAL 90° ELBOW

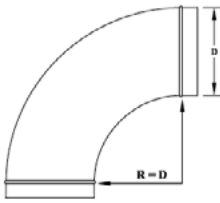

- Galvanized steel per ASTM A653
- Slip fit connections
- Stamped elbow 4" through 12"
- Gorelock elbow 14" through 20"
- 10" Positive W.G.

Size			
6"	8"	10"	12"
14"	16"	18"	20"

SPRIAL 45° ELBOW

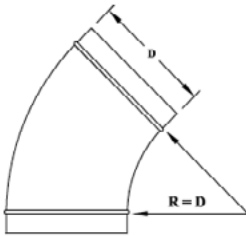

- Galvanized steel per ASTM A653
- Slip fit connections
- Stamped elbow 4" through 12"
- Gorelock elbow 14" through 20"
- 10" Positive W.G.

Size			
6"	8"	10"	12"
14"	16"	18"	20"

SPIRAL DAMPER

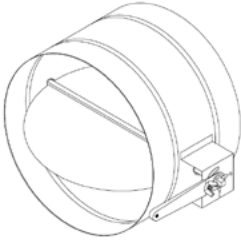

- Galvanized steel per ASTM A653
- Slip fit connections
- Damper in 8" long sleeve, 2" standoff
- 10" Positive W.G.

Size			
6"	8"	10"	12"
14"	16"	18"	20"

SADDLE TAP



- Spiral Saddle Taps
- Galvanized steel per ASTM A653
- 90° saddle tap
- 10" Positive W.G.

Sizes	Spiral Size
6"	8" - 12" pipe
8"	10" - 14" pipe
10"	12" - 18" pipe
12"	14" - 20" pipe
14"	16" - 20" pipe
16"	18" - 20" pipe
18"	20" pipe

SPIRAL REDUCER

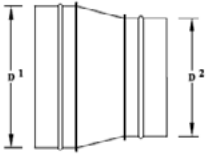

- Galvanized steel per ASTM A653
- Slip fit connections
- 10" Positive W.G.

AIR DISTRIBUTION

		Width									
		6	8	10	12	14	16	18	20	22	24
Height	6										
	8	X									
	10	X	X								
	12	X	X	X							
	14		X	X	X						
	16			X	X	X					
	18				X	X	X				
	20					X	X	X			
	22										
	24										

X = STOCKED SIZES

SPIRAL END CAP

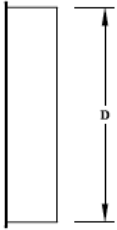

- Galvanized steel per ASTM A653
- Slip fit connections
- 10" Positive W.G.

Size			
6"	8"	10"	12"
14"	16"	18"	20"

SPIRAL COUPLING

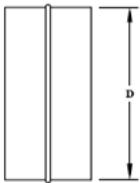

- Galvanized steel per ASTM A653
- Slip fit connections
- 10" Positive W.G.

Size			
6"	8"	10"	12"
14"	16"	18"	20"

SNAPLOCK PIPE



MODEL MC-SL

AIR DISTRIBUTION



- Snap Lock Pipe
- Galvanized steel
- Crimp & bead male connection
- Straight female connection
- Approved to 2" W.G, -1" W.G

30 Gauge

Size	Length
4"	5'
6"	
7"	
8"	
10"	
12"	
14"	
16"	3'
18"	
20"	

26 Gauge

Size	Length
4"	5'
6"	
7"	
8"	
10"	
12"	
14"	
16"	3'
18"	
20"	

MODEL CROWN-111



- Snap Lock Pipe 90° Elbow
- Galvanized steel
- Crimped male connection
- Straight female connection
- Adjustable 90° elbow

30 Gauge

Size
4"
5"
6"
7"
8"
10"

26 Gauge

Size
4"
5"
6"
7"
8"
10"
12"
14"
16"
18"
20"

LINE DAMPER MODEL 275

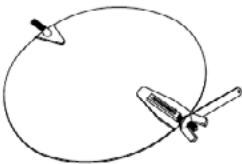

- Line Damper
- Galvanized steel
- 26 gauge
- 1/4" regulators
- Spring bearing with washer, wing nut both sides
- Handle one side

Size					
6"	8"	10"	12"	14"	16"

MODEL RD-TO-RD TPR



- Snap Lock Reducers
- Galvanized steel
- Tapered reducer/increaser
- Transverse connections
- Straight female connections both ends

Sizes			
6" x 4"	6" x 5"	8" x 6"	8" x 7"
10" x 8"	12" x 10"	14" x 12"	16" x 14"
16" x 15"	18" x 16"	20" x 18"	

AIR DISTRIBUTION

MODEL RD-TO-RD FLT



- Galvanized steel
- Flat "pancake" style
- 2-1/2" deep collar
- 2-1/2" base

Sizes		
6" x 4"	8" x 6"	10" x 8"
12" x 10"	14" x 12"	16" x 14"
16" x 15"	18" x 16"	20" x 18"

MODEL TEE

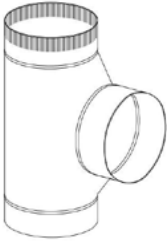

- Galvanized steel
- Transverse connections
- One crimp male end as shown

Sizes
6" × 6" × 6"
8" × 8" × 8"
10" × 10" × 10"
12" × 12" × 12"

MODEL WYE



- Galvanized steel
- Transverse connections
- Straight female connections on large end
- Crimped male connections on both small ends

Sizes
8" × 6" × 6"
10" × 8" × 8"
12" × 10" × 10"

MODEL 273

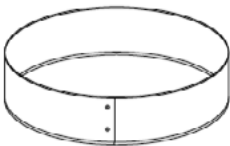

- Snap Lock End Caps
- Galvanized steel
- 26 gauge

Sizes			
4"	5"	6"	7"
8"	10"	12"	14"
16"	18"	20"	

MODEL 711

AIR DISTRIBUTION



- Stick-on Takeoff Fittings for Flat Duct
- Galvanized steel
- 1-1/2" wide flange with gasket and pre-drilled screwholes
- Crimp & bead transverse connection
- Peel off gasket

Size									
4"	5"	6"	7"	8"	10"	12"	14"	16"	18"

MODEL 715



- Stick-on Takeoff Fittings for Flat Duct
- Galvanized steel
- 1-1/2" wide flange with gasket and pre-drilled screwholes
- Crimp & bead transverse connection
- Peel off gasket
- 2" damper handle standoff
- Manual volume damper with 1/4" continuous rod damper axis with locking regulator & grommet at the collar penetrations

Size									
4"	5"	6"	7"	8"	10"	12"	14"	16"	18"

MODEL 717



- Stick-on Takeoff Fittings for Flat Duct
- Galvanized steel
- 1-1/2" wide flange with gasket and pre-drilled screwholes
- Crimp & bead transverse connection
- Peel off gasket
- 2" damper handle standoff
- Manual volume damper with 1/4" continuous rod damper axis with locking regulator & grommet at the collar penetrations
- Scoop penetrates into trunk duct air stream

AIR DISTRIBUTION

Size									
4"	5"	6"	7"	8"	10"	12"	14"	16"	18"

MODEL 311



- Stick-on Takeoff Fittings for Round Duct
- Galvanized steel
- 1-1/2" wide flange with gasket designed to mount on round pipe
- Crimp & bead transverse connection
- Peel off gasket

Size									
4"	5"	6"	7"	8"	10"	12"	14"	16"	18"

MODEL 315

AIR DISTRIBUTION



- Stick-on Takeoff Fittings for Round Duct
- Galvanized steel
- 1-1/2" wide flange with gasket designed to mount on round pipe
- Crimp & bead transverse connection
- Peel off gasket
- 2" damper handle standoff
- Manual volume damper with 1/4" continuous rod damper axis with locking regulator & grommet at the collar penetrations

Size									
4"	5"	6"	7"	8"	10"	12"	14"	16"	18"

MODEL 317



- Stick-on Takeoff Fittings for Round Duct
- Galvanized steel
- 1-1/2" wide flange with gasket designed to mount on round pipe
- Crimp & bead transverse connection
- Peel off gasket
- 2" damper handle standoff
- Manual volume damper with 1/4" continuous rod damper axis with locking regulator & grommet at the collar penetrations
- Scoop penetrates into trunk duct air stream

Size									
4"	5"	6"	7"	8"	10"	12"	14"	16"	18"

MODEL 3726



- Spin-In Fittings
- Galvanized steel
- Spin-in for sheet metal ductwork
- 2" damper handle standoff
- Manual volume damper with 1/4" continuous rod damper axis with locking regulator & grommet at the collar penetrations
- Scoop penetrates into trunk duct air stream

Size							
6"	8"	10"	12"	14"	16"	18"	20"

MODEL 3724



- Spin-In Fittings
- Galvanized steel
- Spin-in for sheet metal ductwork
- 2" damper handle standoff
- Manual volume damper with 1/4" continuous rod damper axis with locking regulator & grommet at the collar penetrations

Size							
6"	8"	10"	12"	14"	16"	18"	20"

MODEL 3300

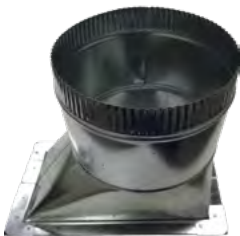

- 45° Takeoffs
- Galvanized steel
- 1" wide flange with gasket and pre-drilled screwholes
- Peel of gasket
- No damper

Size							
6"	8"	10"	12"	14"	16"	18"	20"

MODEL 3300-DS



- 45° Takeoffs
- Galvanized steel
- 1" wide flange with gasket and pre-drilled screwholes
- Peel off gasket
- 2" damper handle standoff
- Manual volume damper with 1/4" continuous rod damper axis with locking regulator & grommet at the collar penetrations

Size							
6"	8"	10"	12"	14"	16"	18"	20"

MODEL 3210



- Bellmouth Takeoffs
- Galvanized steel
- 1" wide flange with gasket and pre-drilled screwholes
- Peel off gasket
- No damper

Size					
6"	8"	10"	12"	14"	16"

MODEL 3210-DS



- Bellmouth Takeoffs
- Galvanized steel
- 1" wide flange with gasket and pre-drilled screwholes
- Peel off gasket
- 2" damper handle standoff
- Manual volume damper with 1/4" continuous rod damper axis with locking regulator & grommet at the collar penetrations

Size					
6"	8"	10"	12"	14"	16"

MODEL 036



- ATCO Flexible Ductwork
- UL 181 Class 1 air duct
- Tough reinforced metallized polyester jacket
- Double lamination polyester core
- R6.0 insulation
- Positive pressure 10" W.G.
- Negative pressure 1" W.G.
- 25' length

Size			
4"	5"	6"	7"
8"	9"	10"	12"
14"	16"	18"	20"

MODEL 1M



- Flexmaster Flexible Ductwork
- UL 181 Class 1 air duct
- Tough reinforced metallized polyester jacket
- PE (Polyethylene) fabric core
- R6 insulation
- Positive pressure 10" W.G.
- Negative pressure 5" W.G. through 16" (1" after)
- 25' length

Size						
6"	8"	10"	12"	14"	16"	18"

MODEL 018



AIR DISTRIBUTION

- ATCO Flexible Ductwork
- UL 181 Class 1 air duct
- Tough reinforced metallized polyester jacket
- R4.2 insulation
- Positive/Negative pressure 12" W.G. 4" through 10"
- Positive/Negative pressure 8" W.G. 12" through 18"
- Universal male/female fittings
- 8ft compressed sections

Size					
6"	8"	10"	12"	14"	16"

MODEL 050



- ATCO Flexible Ductwork
- UL 181 Class 1 air duct
- Double lamination polyester core
- Positive pressure 10" W.G.
- Negative pressure 1" W.G.
- 25' length

Size					
4"	6"	8"	10"	12"	14"

MODEL LS



- Quick Release Straps
- Stainless steel clamp
- Quick release
- Carbon steel screw

Model	Size	Length
LS-104	4"-6"	23"
LS-188	8"-12"	40"
LS-312	14"-20"	64"

FLEXRIGHT



- Flexright Elbow for Flexible Ductwork
- 90° nylon elbow brace
- Universal mount 4" through 16" diameter flex

MODEL L-36, L-48



- Panduit Straps
- Nylon material
- UL94V-2 flammability
- 36" & 48" lengths
- Qty (50) per bag

PANDUIT STRAP TOOL



AIR DISTRIBUTION

CABLE DUCT HANGER



Options
10ft duct hanger cable / 25-150lbs
15ft duct hanger cable / 25-150lbs
10ft duct hanger cable / 25-250lbs
15ft duct hanger cable / 25-250lbs

DUCT HANGER CLIPS



- Zinc plated steel
- Used for rectangular ductwork & equipment
- 25-150 lbs

DUCT STRAP



- Galvanized steel
- 1" x 100ft duct strap
- Plenum rated

FOIL TAPE



AIR DISTRIBUTION

DUCT SEALANT



SCREWS



7 × 1/2"



10 × 3/4"

MODEL DTQP



- Fan Powered Units with Electric Heat (parallel)
- Parallel fan powered unit
- Electric heat
- Airflow switch
- Door interlock disconnect switch
- Inlet flow cross sensor
- Controls enclosure
- PSC fan motor with speed controller
- Throwaway construction filter
- 1/2" Elastomeric liner / Fiber free

Sizes				
2006	277/1	3KW - 1 Stage	6" Inlet	14" × 11" Outlet
3008	277/1	3KW - 1 Stage	8" Inlet	14" × 11" Outlet
3008	277/1	6KW - 1 Stage	8" Inlet	14" × 11" Outlet
4010	480/3	9KW - 2 Stage	10" Inlet	14" × 11" Outlet

MODEL DESV



- Single Duct Terminal Units
- Single duct variable volume valve
- Inlet flow cross sensor
- Controls enclosure
- 1/2" Elastomeric liner / Fiber free

Sizes	
6" Inlet	12" × 8" Outlet
8" Inlet	12" × 10" Outlet
10" Inlet	14" × 12 ½" Outlet
12" Inlet	16" × 15" Outlet
14" Inlet	20" × 17 ½" Outlet
16" Inlet	24" × 18" Outlet

HOT WATER COILS



For Model DESV

Sizes	
6"	1 Row
8"	2 Row
10"	2 Row
12"	2 Row
14"	2 Row
16"	2 Row

- Hot water heat coils
- 1/2" diameter 0.016" thick copper
- Aluminum plate fins, 10 per inch
- 20 gauge galvanized casing
- Max working pressure 360 PSIG
- Max water 200° F
- S & Drive Connection

TERMINAL UNITS

PNEUMATIC CONTROLS



For Model DESV

- Pressure independent pneumatic controls
- Direct or reverse acting
- Operated on control air pressure of 15-25 PSI
- Pneumatic actuator

Options
Controller Only
Pneumatic Control Kit (controller, actuator, tubing)

MODEL T-3107299



- Controls Enclosure Only
- NEMA-1 controls enclosure
- Multiple knockouts from 7/16" to 1-1/8"

We don't "value engineer" — we engineer value.

Our innovative engineers continuously explore more cost-effective, value-added product solutions.



Our engineers continuously develop and introduce new product solutions based on the input they receive from more than 175 Greenheck manufacturer representatives around the world who listen carefully to what you need. State-of-the-art computer modeling and extensive prototype testing ensure that our newest products offer more efficient performance and easy, lower-cost installation. Whether it's developing compact, quieter fans with the lowest industry sound levels, the most advanced energy recovery ventilators available, or more effective laboratory exhaust systems, Greenheck engineers always have one goal in mind: deliver value that exceeds your expectations.



We have the world's most comprehensive line of top-quality air movement, control and conditioning products.

No other manufacturer offers you as many options for air movement, control and conditioning as Greenheck. Specifying engineers and contractors can rely on us for products that stand at the forefront of technology and performance. To maintain your trust, we assign a knowledgeable product manager, a talented group of engineers and an experienced customer service team to each of our product areas:

- Roof Mounted Fans & Gravity Ventilators
- In-line, Ceiling & Sidewall Fans
- Utility, Centrifugal & Radial Blowers
- Fume Exhaust Systems
- Laboratory Exhaust Systems
- Energy Recovery Ventilators
- Make-Up Air
- Packaged Rooftop Units
- Indoor Air Handlers & Fan Coils
- Coils
- Duct Heaters
- Dampers
- Louvers

MODEL SP



- Ceiling cabinet fan
- Gravity damper
- Plug disconnect
- 115/1 voltage
- Designer grille
- Insulated housing on Model "A"

Sizes	
SP-LP0511-1	50-110 CFM @ 0.1 SP
SP-B70	70 CFM @ 0.1 SP
SP-B80	80 CFM @ 0.1 SP
SP-B90	90 CFM @ 0.1 SP
SP-B110	110 CFM @ 0.1 SP
SP-B150	150 CFM @ 0.1 SP
SP-B200	200 CFM @ 0.1 SP
SP-A125	125 CFM @ 0.1 SP
SP-A200	200 CFM @ 0.1 SP
SP-A290	290 CFM @ 0.1 SP
SP-A390	390 CFM @ 0.1 SP
SP-A510	510 CFM @ 0.1 SP
SP-A710	710 CFM @ 0.1 SP
SP-A1050	1,050 CFM @ 0.1 SP

MODEL CSP

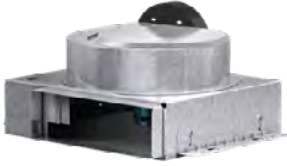

- Inline cabinet ceiling fan
- Gravity damper
- Plug disconnect
- 115/1 voltage
- Insulated housing on Model "A"

Sizes	
CSP-B110	110 CFM @ 0.1 SP
CSP-B150	150 CFM @ 0.1 SP
CSP-B200	200 CFM @ 0.1 SP
CSP-A110	110 CFM @ 0.1 SP
CSP-A200	200 CFM @ 0.1 SP
CSP-A250	250 CFM @ 0.1 SP
CSP-A290	290 CFM @ 0.1 SP
CSP-A390	390 CFM @ 0.1 SP
CSP-A410	410 CFM @ 0.1 SP
CSP-A510	510 CFM @ 0.1 SP
CSP-A710	710 CFM @ 0.1 SP
CSP-A780	780 CFM @ 0.1 SP
CSP-A1050	1,050 CFM @ 0.1 SP

Models SP-LP0511-1 & SP-LP0511L-1



The Multipurpose High-Performance Solution

Our code-compliant-verified ventilation fans help ensure that you meet code, exceed your customers' expectations, and eliminate costly callbacks.

Exclusive Features:

- The SP-LP Series is powered by an electronically commutated motor (ECM) with **Constant CFM** adaptive, variable speed technology programmed to overcome the static pressure associated with common residential installation scenarios (0.4 in. wg and above). The motor reacts to increased static pressure by increasing its speed to ensure you have the airflow required to remove unhealthy air and moisture and meet the latest energy codes.
- Greenheck's code-compliant-verified ventilation fans are **designed, tested and certified (air & sound) for 0.4 in. wg and above**, so there are no surprises. You get the airflow that you paid for and eliminate callbacks.
- The SP-LP series is the most powerful low-profile exhaust fan on the market, offering airflow up to **110 cfm**.



Additional Benefits

- The virtually silent EC motor features three built-in high-speed airflow settings of 50, 80, and 110 cfm.
- 3 1/2-inch housing depth – the low profile is ideal for wall or ceiling installations, and easily fits in a 2x4 stud bay.
- L-shaped bracket for support and ease of installation.
- UL listed for tub/shower enclosure when GFCI protected.
- SP-LP0511L-1 includes a 10W dimmable LED chip panel, 750 lumens, 3000K warm white color temperature, and Rated Life of 50,000 hours.
- 3-year warranty on EC motor and parts, excluding light.
- CRD-300WT, a UL263 certified Ceiling Radiation Damper compatible with both the lighted and non-lighted SP-LP-1 models.

SP-LP0511-1 & SP-LP0511L-1 Performance

Highlighted ratings at **0.25 in. wg** are required to meet ENERGY STAR® certification and **0.4 in. wg** represents the static pressure found in common installations.

Model	ENERGY STAR®	CFM Selection	RPM	Max Amps	Max Watts	CFM/Static Pressure in Inches wg				
						0.1	0.25	0.4	0.5	
SP-LP0511-1	☆	50	685	0.19	12.7	CFM	50	50	50	50
						Sones	<0.3	0.8	1.5	2.5
						CFM/Watt	12.7	8.4	5.8	4.8
						Watts	4.5	7	10	12.3
		80	773	0.26	17.4	CFM	80	80	80	80
						Sones	0.7	1.4	2	2.5
						CFM/Watt	12.8	8.2	6	5
						Watts	6.6	10.7	14.6	17.4
		110	939	0.33	22.5	CFM	110	110	109	102
						Sones	1.5	2.5	3	3
						CFM/Watt	9.3	6.7	5.3	4.8
						Watts	12.4	17.3	21.4	22.5
SP-LP0511L-1	☆	50	720	0.20	12.9	CFM	50	50	50	50
						Sones	0.4	0.8	1.4	2
						CFM/Watt	13	8	5.7	4.8
						Watts	4.5	7.5	10.4	12.9
		80	835	0.27	18.2	CFM	80	80	80	73
						Sones	0.9	1.4	2	2.5
						CFM/Watt	11.2	7.7	5.8	4.9
						Watts	7.7	11.5	15.4	18.2
		110	1020	0.32	21.9	CFM	110	110	105	78
						Sones	2	2.5	2.5	2.5
						CFM/Watt	8.3	6.2	5.1	3.7
						Watts	14	19	21.9	21

Certified for Air and Sound through the Home Ventilating Institute. Airflow data reflects all performance points that would meet or exceed the ASHRAE 62.2 minimum requirement of 50 cfm for bathroom exhaust.



Our Commitment

As a result of our commitment to continuous improvement, Greenheck reserves the right to change specifications without notice.

Product warranties can be found online at Greenheck.com, either on the specific product page or in the literature section of the website at Greenheck.com/Resources/Library/Literature.

Visit Greenheck.com/ceiling-exhaust-fans to learn more.



FANS - PERFORMANCE



Power Ratings and Certifications



SP Model	115V/60Hz	115V/50Hz	220-240V/50Hz	220-240V/60Hz	277V	EC Motor	Output Power (Watts or HP)	ASHRAE 90.1 Compliant
SP-A70	317723						2.25W	Yes
SP-A90	312280						3.61W	Yes
SP-A110	312281						4.57W	Yes
SP-A125	312282						6.14W	Yes
SP-A50-90-VG	327959	327959	327959	327959		Yes	12W	Yes
SP-A90-130-VG	327960	327960	327960	327960		Yes	12W	Yes
SP-A200	1039434						18.65W	Yes
SP-A250	1039435						1/30	Yes
SP-A390	304842	304842					1/12	Yes
SP-A390-VG	329508	329508	329508	329508	329508	Yes	1/10	Yes
SP-A410	301817						1/19	Yes
SP-A510	310225		311741	311741			1/12	Yes
SP-A510-VG	329557	329557	329557	329557	329557	Yes	17/100	Yes
SP-A700	318873						1/7	No
SP-A700-VG	328174	328174	328174	328174	328174	Yes	29/100	Yes
SP-A710	301816						1/6	No
SP-A710-VG	329558	329558	329558	329558	329558	Yes	27/100	Yes
SP-A780	309133						1/3	No
SP-A900	318871						1/6	No
SP-A1050	318863						1/4	No
SP-A1050-VG	328173	328173	328173	328173	328173	Yes	1/3	Yes
SP-A1300	329516						1/7	No
SP-A1550	318865		329309	329309			3/4	No
SP-B50	315037						1W	Yes
SP-B70	315038						3W	Yes
SP-B80	1039948						5W	Yes
SP-B90	1039440						5W	Yes
SP-B110	1039437						8W	Yes
SP-B110ES	356655						9W	Yes
SP-B150	1039438						18W	Yes
SP-B200	318872						1/30	Yes

*Note: All motors are rated for continuous use

Greenheck Fan Corporation certifies that the SP models shown herein are licensed to bear the AMCA seal. The ratings shown are based on tests and procedures performed in accordance with AMCA Publication 211 and AMCA Publication 311 and comply with the requirements of the AMCA Certified Ratings Program. The SP models are not AMCA certified with 50 hertz motors.



CSP Model	115V/60Hz	115V/50Hz	220-240V/50Hz	220-240V/60Hz	277V	EC Motor	Output Power (Watts or HP)	ASHRAE 90.1 Compliant
CSP-A110	312281						4.57W	Yes
CSP-A125	312282						6.14W	Yes
CSP-A200	316481						18.65W	Yes
CSP-A250	316480						1/30	Yes
CSP-A390	304842	304842					1/12	Yes
CSP-A390-VG	329508	329508	329508	329508	329508	Yes	1/10	Yes
CSP-A410	301817						1/19	Yes
CSP-A510	310225		311741	311741			1/12	Yes
CSP-A510-VG	329557	329557	329557	329557	329557	Yes	17/100	Yes
CSP-A700	318873						1/7	No
CSP-A700-VG	328174	328174	328174	328174	328174	Yes	29/100	Yes
CSP-A710	301816						1/6	No
CSP-A710-VG	329558	329558	329558	329558	329558	Yes	1/4	Yes
CSP-A780	309133						1/3	No
CSP-A900	318871						1/6	No
CSP-A1050	318863						1/4	No
CSP-A1050-VG	328173	328173	328173	328173	328173	Yes	1/3	Yes
CSP-A1300	329516						3/7	No
CSP-A1550	318865						3/4	No
CSP-A1750	318864						3/4	No
CSP-A2150	318864						3/4	No
CSP-A3300-VG	356599	356599	356599	356599	356599	Yes	1	Yes

*Note: All motors are rated for continuous use



Greenheck Fan Corporation certifies that the CSP models shown herein are licensed to bear the AMCA seal. The ratings shown are based on tests and procedures performed in accordance with AMCA Publication 211 and comply with the requirements of the AMCA Certified Ratings Program. The CSP models are not AMCA certified with 50 hertz motors.



Models SP and CSP are listed electric fans (UL/cUL 507). Ceiling Exhaust Fans are also UL Listed for above bathtub/shower with GFCI branch protected circuit. File no. E33599. Note: SP/CSP fans are rated for direct contact with insulation.

Products that earn the ENERGY STAR® prevent greenhouse gas emissions by meeting strict energy efficiency guidelines set by the U.S. Environmental Protection Agency and the U.S. Department of Energy.



Fans that are ENERGY STAR certified include: SP-A70, SP-A90, SP-A110, SP-A125, SP-A200, SP-A250, SP-B50, SP-B70, SP-B80, SP-B90, SP-B110ES, SP-A50-90-VG, SP-A90-130-VG, CSP-A110, CSP-A125, CSP-A200, CSP-A390-VG

Model SP-A Premium Ceiling Exhaust Fan



Model	ENERGY STAR®	Control Voltage	RPM	Amps*	Max.Input Watts*	CFM / Static Pressure in Inches wg											
						0	0.1	0.125	0.25	0.375	0.5	0.625	0.75	0.875	1.0	1.25	
SP-A780			1600	3.30	348	CFM	812	782	775	741	704	665	625	581			
						Sones	8.5	8.5	8.5	8.0	8.0	8.0	8.0	8.0			
SP-A900			1055	2.78	301	CFM	971	925	915	866	814	754	694	621	433	327	
						Sones	6.0	5.5	5.0	5.0	5.0	5.0	5.5	5.5	6.0	6.5	
SP-A1050			1250	4.05	438	CFM	1144	1098	1084	1032	987	935	875	809	734	561	
						Sones	7.0	7.0	7.0	7.0	6.5	6.5	6.5	6.5	7.0	7.0	
SP-A1050-VG		6	1050	1.94	120	CFM	838	789	779	735	685	632	579				
						Sones	4.0	4.0	4.0	4.0	4.0	4.5	5.0				
		10	1225	3.75	240	CFM	1162	1106	1092	1023	944	831	668				
						Sones	7.5	7.0	7.0	7.0	6.5	6.0	5.0				
SP-A1300			1535	5.33	607	CFM	1396	1360	1348	1304	1260	1216	1168	1111	1045	971	701
						Sones	10.0	10.0	10.0	9.5	9.5	9.5	9.0	9.0	9.0	8.5	8.5
SP-A1550			1695	6.07	695	CFM	1559	1518	1503	1456	1402	1346	1300	1239	1172	1095	876
						Sones	11.5	11.0	11.0	11.0	10.5	10.0	10.0	9.5	9.5	9.0	8.5

*Amp and Watt draw is approximate and may vary based on motor manufacturer. Above performance is for 115V.

Performance certified is for model SP exhaust for installation type B: Free inlet, Ducted outlet. Performance ratings include the effects of an inlet grille and backdraft damper. Speed (rpm) shown is nominal. Performance is based on actual speed of test. The sound ratings shown are loudness values in spherical fan sones at 5 ft (1.5 m) in a spherical free field calculated per Annex B of AMCA 311. Values shown are for installation type B: free inlet spherical fan sone levels.

Model SP-B Deluxe and Standard Ceiling Exhaust Fan



Model SP-B

Model SP-B Dimensions

Model	A	B	C	D	E	Grille	Unit Weight
50, 70, 80	13 ³ / ₈ (352)	11 ¹ / ₂ (292)	7 (179)	6 (152)	1 ¹ / ₄ (32)	14 ⁷ / ₈ x 13 ¹ / ₄ (378 x 337)	9 (4)
90, 110, 110ES, 150, 200	13 ³ / ₈ (352)	11 ¹ / ₂ (292)	7 (179)	6 (152)	1 ¹ / ₄ (32)		10 (5)

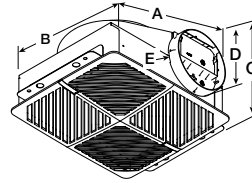

All dimensions are in inches (millimeters) and weight in pounds (kilograms). Mounting bracket width is 1 1/2 in. (38 mm). For complete dimensional information, see CAPS® submittal drawings.

◆Continuous Ventilation Compatible: Low speed continuous operation is adjustable from 30 cfm to full rated fan speed.

*Amp and Watt draw is approximate and may vary based on motor manufacturer. Below performance is for 115V.



Model SP-B Performance

Model	ENERGY STAR®	Continuous Ventilation Compatible	RPM	Amps*	Max. Input Watts*	CFM / Static Pressure in Inches wg																				
						0	0.1	0.125	0.25	0.375	0.5	0.625	0.75	0.875	1.0											
SP-B50	☆		580	0.13	15.9	CFM	79	63	60	45	28															
						Sones	<0.3	0.4	0.5	1.1	2.5															
						CFM/Watt*	4.97	4.04	3.87	2.99	1.92															
						Watt*	15.89	15.59	15.50	15.06	14.57															
SP-B70	☆		675	0.16	17.1	CFM	89	75	71	54	35															
						Sones	0.8	0.8	0.9	1.4	2.0															
						CFM/Watt*	5.20	4.46	4.25	3.27	2.27															
						Watts*	17.10	16.80	16.70	16.50	15.41															
SP-B80	☆	◆	900	0.16	18.6	CFM	94	81	77	62	46															
						Sones	0.8	0.9	0.9	1.3	2.0															
						CFM/Watt*	5.05	4.40	4.21	3.44	2.71															
						Watts*	18.60	18.40	18.30	18.00	16.95															
SP-B90	☆		700	0.18	21.1	CFM	104	92	89	72	57															
						Sones	1.0	1.0	1.0	1.5	2.0															
						CFM/Watt*	4.93	4.40	4.24	3.48	2.88															
						Watts*	21.10	20.90	21.00	20.70	19.77															
SP-B110			950	1.14	80.2	CFM	133	114	110	97	95	94	91	85	72	50										
						Sones	1.5	1.5	1.5	2.0	2.0	2.0	3.0	3.5	4.0	4.5										
						CFM	130	118	115	100	86	73	58	37												
						Sones	1.5	1.5	1.5	2.0	2.5	3.0	3.5	4.0												
SP-B110ES	☆	◆	650	0.25	29.7	CFM	4.38	4.03	3.95	3.50	3.08	2.70	2.24	1.48												
						Sones	1.5	1.5	1.5	2.0	2.5	3.0	3.5	4.0												
						CFM/Watt*	29.65	29.27	29.15	28.57	27.89	27.08	25.95	24.97												
						Watt*	160	156	155	154	152	149	147	138												
SP-B150			1050	1.70	128	CFM	2.5	2.5	2.5	3.0	3.5	3.5	4.0	4.5	5.0											
						Sones	2.5	2.5	2.5	3.0	3.5	3.5	4.0	4.5	5.0											
						CFM	208	211	212	216	216	210	197	176	157	130										
						Sones	5.0	5.5	5.5	6.0	6.5	6.5	6.5	6.5	6.0	6.0										
SP-B200			980	2.41	185	CFM	208	211	212	216	216	210	197	176	157	130										
						Sones	5.0	5.5	5.5	6.0	6.5	6.5	6.5	6.5	6.0	6.0										
						CFM	208	211	212	216	216	210	197	176	157	130										
						Sones	5.0	5.5	5.5	6.0	6.5	6.5	6.5	6.5	6.0	6.0										

Performance certified is for model SP exhaust for installation type B: Free inlet, Ducted outlet. Performance ratings include the effects of an inlet grille and backdraft damper. Speed (rpm) shown is nominal. Performance is based on actual speed of test. The sound ratings shown are loudness values in spherical fan sones at 5 ft (1.5 m) in a spherical free field calculated per Annex B of AMCA 311. Values shown are for installation type B: free inlet spherical fan sone levels.

Model CSP-A Premium Inline Cabinet Fan



Model CSP-A Dimensions

Model	A	B	C	D	E	F	G	Unit Weight
110, 125	13¼ (337)	10½ (270)	9 (229)	8 (203)	6 (152)	12 (305)	9¼ (235)	16 (7)
200, 250, 390, 390-VG	14 (356)	11½ (302)	11¼ (286)	8 (203)	8 (203)	12½ (327)	10 (254)	23 (10)
410, 510, 510-VG, 710-VG	18 (457)	14¾ (365)	14½ (368)	8 (203)	8 (203)	16½ (429)	13¼ (337)	36 (16)
700, 700-VG	23¾ (600)	11½ (295)	11½ (295)	19½ (495)	8 (203)	22½ (575)	10½ (267)	34 (15)
710, 780	18 (457)	14¾ (365)	14½ (368)	10 (254)	8 (203)	16½ (429)	13¼ (337)	36 (16)
900, 1050, 1050-VG, 1300, 1550	23¾ (603)	14¾ (365)	14½ (368)	17¼ (443)	8 (203)	22½ (575)	13¼ (337)	59 (27)
1750, 2150	35 (889)	14¾ (375)	14¾ (375)	28 (711)	6 (152)	32¾ (832)	13 (330)	68 (31)
3300-VG	45½ (1156)	16½ (419)	16½ (419)	40 (1016)	11 (279)	43¼ (1099)	14½ (371)	122 (55)

All dimensions are in inches (millimeters) and weight in pounds (kilograms). Inlet and outlet connection widths are 1 in. (25 mm). Mounting bracket width is 1½ in. (38 mm).
For complete dimensional information, see CAPS® submittal drawings.

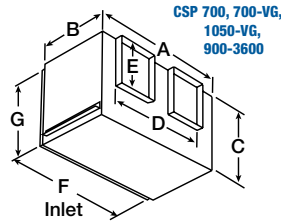
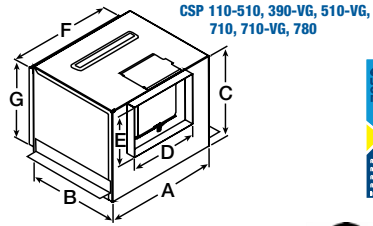

Model	ENERGY STAR®	Control Voltage	RPM	Amps*	Max. Input Watts*	CFM / Static Pressure in Inches wg																					
						0	0.1	0.125	0.25	0.375	0.5	0.625	0.75	0.875	1.0												
CSP-A110	☆		950	0.16	19.7	CFM	131	111	107	85	38																
						Sones	0.8	0.8	0.8	0.9	0.9																
						CFM/Watt*	6.65	5.78	5.61	4.70	2.39																
						Watts*	19.7	19.2	19.1	18.1	15.9																
CSP-A125	☆		980	0.19	22.4	Sones	1.1	1.1	1.1	1.0	1.2																
						CFM/Watt*	6.64	5.82	5.65	4.79	2.61																
						Watts*	22.4	22.2	22.1	21.5	19.9																
						CFM	264	240	235	214	191	154	98	62													
CSP-A200	☆		825	0.48	56.8	Sones	0.6	0.4	0.5	0.9	1.0	1.3	1.5	1.5													
						CFM/Watt*	4.65	4.28	4.20	3.89	3.58	3.04	2.10	1.38													
						Watts*	56.8	56.1	55.9	55.0	53.4	50.7	46.7	45.1													
						CFM	266	246	241	221	205	187	165	132													
CSP-A250			1000	0.79	67	Sones	0.9	1.0	1.0	2.0	2.5	3.0	2.5	2.5													
						CFM/Watt*	66.5	65.6	65.4	64.0	62.7	61.2	59.4	56.6													
						Watts*	67	66.5	66.4	64.0	62.7	61.2	59.4	56.6													
						CFM	412	400	397	382	363	339	324	309													
CSP-A390			1350	1.33	161	Sones	2.0	2.0	2.0	2.5	3.0	4.0	4.5	4.5													
						CFM/Watt*	160.8	158.5	157.9	152.4	147.9	141.8	135.4	130.0													
						Watts*	161	160.8	160.7	157.9	152.4	147.9	141.8	135.4	130.0												
						CFM	270	244	239	212	191	164	137	104	78	57											
CSP-A390-VG	☆	6	870	0.66	42	Sones	0.3	<0.3	0.3	0.6	0.7	1.1	1.4	2.0	2.0	2.0	2.5										
						CFM/Watt*	22.8	25.0	25.2	27.0	29.8	33.4	36.3	39.6	40.6	42.2											
		Watts*	41.7	40.0	39.5	36.9	35.0	33.5	32.2	30.7	29.0	27.1															
		CFM	417	400	395	369	350	335	322	307	290	271															
Sones	1.2	1.3	2.0	1.3	0.9	1.4	2.0	2.5	3.0	3.0																	
Watts*	77.1	79.3	80.3	82.9	83.5	86.8	89.6	93.1	94.9	97.7																	

*Amp and Watt draw is approximate and may vary based on motor manufacturer. Above performance is for 115V.

Model CSP-A Premium Inline Cabinet Fan



Model	ENERGY STAR®	Control Voltage	RPM	Amps*	Max. Input Watts*	CFM / Static Pressure in Inches wg																				
						0	0.1	0.125	0.25	0.375	0.5	0.625	0.75	0.875	1.0	1.25	1.5									
CSP-A410			1000	1.87	132	CFM	447	441	403	364	317	217														
						Sones	1.5	1.5	1.5	2.0	2.0	2.0														
						Watts*	132.2	131.7	128.7	125.6	120.5	112.4														
CSP-A510			1070	3.11	218	CFM	545	514	506	464	405	324														
						Sones	2.5	2.0	2.0	2.0	2.0	2.5														
						Watts*	218.2	214.3	213.3	207.0	196.4	182.8														
CSP-A510-VG			850	0.86	55	CFM	428	358	338	238																
						Sones	0.8	0.6	0.5	0.3																
						Watts*	54.8	48.9	47.0	35.8																
			1275	2.40	160	CFM	621	590	583	540	479	414	328													
						Sones	1.5	1.4	1.4	1.3	1.2	1.5	2.0													
						Watts*	154.4	159.6	160.1	156.1	140.7	123.1	99.9													
CSP-A700			1035	3.16	368	CFM	866	827	817	758	720	694	648	594	419	330										
						Sones	1.1	1.1	1.1	1.1	1.2	1.5	2.0	2.5	3.0											
						Watts*	367.9	351.0	347.0	330.0	321.8	312.0	298.3	284.1	249.6	231.4										
CSP-A700-VG			1275	1.83	110	CFM	625	570	558	504	450	402	348	261	213	167	67									
						Sones	<0.3	<0.3	<0.3	<0.3	<0.3	0.8	1.1	1.5	2.0	2.5	3.0									
						Watts*	55.6	58.7	60.0	63.5	69.4	76.5	83.8	89.5	95.3	101.0	108.2									
			10	1450	3.53	216	CFM	895	857	848	803	760	725	688	647	604	556	479								
							Sones	1.0	1.0	1.0	1.0	1.0	1.2	1.5	1.5	2.0	2.5	3.0								
							Watts*	157.1	160.6	161.3	168.5	169.4	173.1	179.9	187.1	193.6	201.4	215.3								
CSP-A710			1080	4.40	333	CFM	737	698	688	635	567	475	334													
						Sones	2.5	2.5	2.5	2.5	2.0	2.0	2.0													
						Watts*	332.5	324.1	322.0	310.8	295.8	277.4	255.2													
CSP-A710-VG			925	1.08	68	CFM	470	415	405	322																
						Sones	0.6	0.4	0.4	0.4																
						Watts*	67.8	61.2	60.6	49.0																
			1450	3.51	236	CFM	730	699	690	654	622	574	514	446	349											
						Sones	2.0	2.0	2.0	2.0	2.0	2.0	2.5	3.0	3.0											
						Watts*	236.0	234.2	231.4	223.1	218.9	200.8	180.0	156.8	119.9											
CSP-A780			1600	3.77	496	CFM	813	784	777	742	707	672	638	603	567	527										
						Sones	3.0	3.0	3.0	3.0	3.0	3.0	3.0	3.0	3.0	3.0	3.5									
						Watts*	496.4	493.0	492.2	488.0	467.5	453.1	441.8	423.1	407.2											
CSP-A900			895	2.91	318	CFM	930	875	865	811	755	686	558	411	290											
						Sones	0.4	0.3	0.3	0.3	0.4	0.9	1.4	2.0	2.5											
						Watts*	318.3	308.1	305.5	297.7	289.8	278.0	260.9	245.7	225.5											
CSP-A1050			1070	4.29	467	CFM	1108	1059	1050	1001	958	912	857	793	723	498										
						Sones	1.1	1.0	1.0	1.0	1.1	1.3	1.5	2.0	2.0	3.0										
						Watts*	466.8	451.2	450.1	440.1	430.8	419.3	404.3	389.1	372.7	329.6										
CSP-A1050-VG			1050	1.90	115	CFM	805	754	741	689	642	597	547													
						Sones	<0.3	<0.3	<0.3	0.4	0.5	1.0	1.5													
						Watts*	79.8	85.2	85.0	91.4	97.4	105.5	114.9													
			10	1225	3.85	241	CFM	1131	1105	1092	1047	998	900	758												
							Sones	1.0	0.9	0.9	1.0	1.2	1.3	1.4												
							Watts*	220.7	231.5	231.5	239.7	239.9	216.7	173.9												
CSP-A1300			1300	6.82	761	CFM	1313	1283	1277	1245	1213	1181	1144	1098	1046	978	791									
						Sones	2.0	2.0	2.0	2.0	2.0	2.0	2.5	2.5	3.0	3.5	3.5									
						Watts*	761.3	728.3	720.9	694.0	667.0	640.5	608.3	578.6	542.9	509.9	416.3									
CSP-A1550			1625	8.18	934	CFM	1735	1689	1680	1627	1570	1511	1453	1387	1322	1257	1085									
						Sones	5.0	5.0	5.0	4.5	4.0	4.5	4.5	4.5	4.5	4.5	5.0									
						Watts*	934.3	902.7	899.6	865.1	837.0	803.2	774.9	736.0	698.4	664.3	577.7									
CSP-A1750			1325	10.30	1153	CFM	2012	1954	1943	1871	1805	1738	1669	1593	1508	1416	1152	705								
						Sones	3.0	3.0	3.0	3.0	3.0	3.0	3.5	3.5	4.0	4.5	5.0	5.0								
						Watts*	1152.8	1105.0	1095.6	1037.8	989.5	947.5	909.7	867.6	823.5	781.5	673.3	520.0								
CSP-A2150			790	11.55	1285	CFM	2167	2110	2082	2014	1963	1915	1853	1783	1702	1614	1400	887								
						Sones	3.0	3.0	3.0	3.0	3.0	3.0	3.5	3.5	4.0	4.0	4.5	5.0	5.0							
						Watts*	1284.7	1244.2	1214.2	1150.0	1111.8	1062.9	1010.9	961.2	912.8	866.3	764.6	556.8								
CSP-A3300-VG			820	6.18	507.3	CFM	2445	2367	2344	2264	2195	2149	2072	1965	1851	1664										
						Sones	2.5	2.5	2.0	2.0	2.5	3.0	3.0	3.5	4.0	4.0										
						Watts*	342.9	350.5	353.3	375.8	397.9	408.6	433.6	457.5	476.7	507.3										
			10	1090	12.34	1048.9	CFM	3401	3342	3312	3271	3154	3083	2956	2879	2766	2439									
							Sones	5.0	5.0	4.5	4.5	4.0	4.5	4.5	4.5	5.0	4.5									
							Watts*	955.4	972.8	979.8	1007.7	1023.1	1048.8	1000.7	966.9	928.3	803.9									

*Amp and Watt draw is approximate and may vary based on motor manufacturer. Above performance is for 115V.

Performance certified is for model CSP inline for installation type D: Ducted inlet, Ducted outlet. Performance ratings include the effects of a backdraft damper. Speed (rpm) shown is nominal. Performance is based on actual speed of test. The sound ratings shown are loudness values in spherical fan sones at 5 ft (1.5 m) in a spherical free field calculated per Annex B of AMCA 311. Values shown are for installation type D: ducted inlet spherical fan sone levels. Ratings do not include the effect of duct end correction. Ratings are based on 10 ft of insulated duct.

MODEL CE-12-DS



- Direct Drive Propeller Wall Fan
- 3 speed direct drive shutter mounted fan
- 12" diameter
- 115/1 voltage
- Gravity damper

Size
560 / 710 / 825 CFM

MODEL SQ-100-VG



- Direct Drive Centrifugal, In-line Fans
- Square inline centrifugal fan
- UL listed for electrical
- Steel construction
- Two removable access panels
- Backward inclined centrifugal wheel
- NEMA-1 disconnect
- ODP motor (EC motor on SQ-100-VG)
- 115/1 voltage

	Sizes	HP
SQ-80*	400 CFM @ 0.1 SP	1/12 HP
SQ-90*	670 CFM @ 0.1 SP	1/10 HP
SQ-95*	845 CFM @ 0.1 SP	1/8 HP
SQ-100-VG	1400 CFM @ 0.1 SP	1/4 HP

*OPTIONAL MODEL BD-330 12 × 12 DAMPER, 6AMP SPEED CONTROLLER

FANS

Dimensions



SQ DIRECT DRIVE

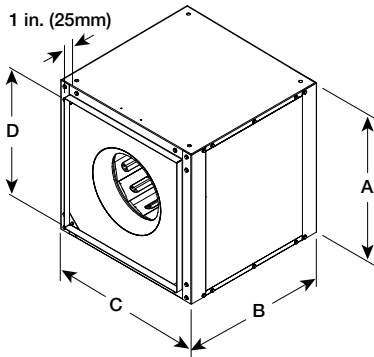

BSQ BELT DRIVE

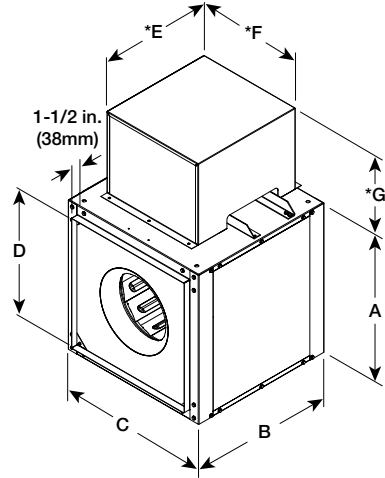

Model	Fan Size	A	B	C	D	*E	*F	*G	Damper Size	Max Fan Weight [^]
SQ Direct Drive	60, 70	12	13	12	8-7/8	-	-	-	9 x 9	26
	80, 90, 95	15	16	15	11-7/8	-	-	-	12 x 12	41
	97, 98, 99	15	21	15	11-7/8	-	-	-	12 x 12	49
	100	17	21	17	13-7/8	-	-	-	14 x 14	56
	120	19	21	19	15-7/8	-	-	-	16 x 16	67
	130 (HP)	21	21	21	17-7/8	-	-	-	18 x 18	67
	140 (HP)	23	22	23	19-7/8	-	-	-	20 x 20	104
	160 (HP)	26	26	26	22-7/8	-	-	-	23 x 23	160
BSQ Belt Drive	70, 80, 90	17-1/8	21	17-1/8	11-7/8	17-3/4	13	13-1/4	12 x 12	106
	100	17-1/8	21	17-1/8	13-7/8	17-3/4	13	13-1/4	14 x 14	107
	120	19-1/8	21	19-1/8	15-7/8	20	17	13-1/4	16 x 16	124
	130 (HP)	21-1/8	21	21-1/8	17-7/8	20	17	13-1/4	18 x 18	131
	140 (HP)	23-1/8	22	23-1/8	19-7/8	20	17	13-1/4	20 x 20	146
	160 (HP)	26-1/8	26	26-1/8	22-7/8	20	17	13-1/4	23 x 23	188
	180 (HP)	27-1/8	28	27-1/8	23-7/8	20	17	13-1/4	24 x 24	195
	200 (HP)	31-1/8	32	31-1/8	27-7/8	30	20	16	28 x 28	246
	240 (HP)	38-1/8	34	38-1/8	34-7/8	30	20	16	35 x 35	350
	300 (HP)	46	38	46	41-7/8	34	22	18	42 x 42	537
360 (HP)	52	42	52	47-7/8	34	22	18	48 x 48	686	
420	58	50	58	53-7/8	34	22	18	54 x 54	789	

All dimensions in inches and weight is shown in pounds. *Motor cover is optional. Size may be greater depending on motor. ^Weight shown is standard galvanized construction and largest cataloged open drip proof motor.

Performance



SQ DIRECT DRIVE

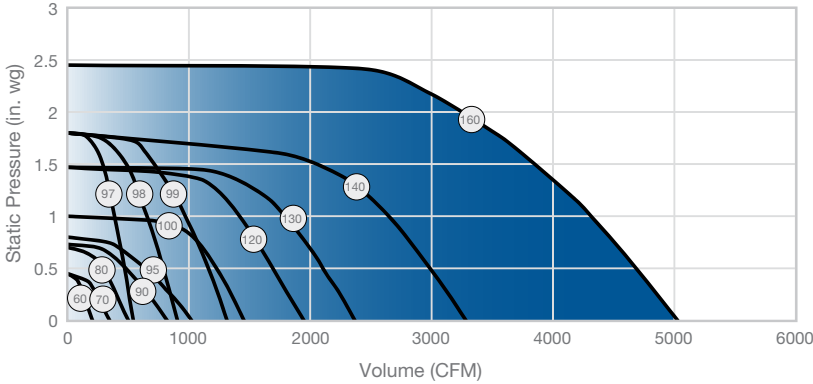

BSQ BELT DRIVE

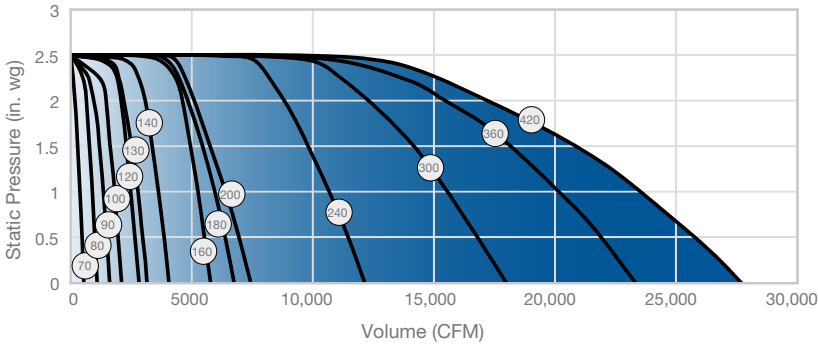

BSQ-HP BELT DRIVE

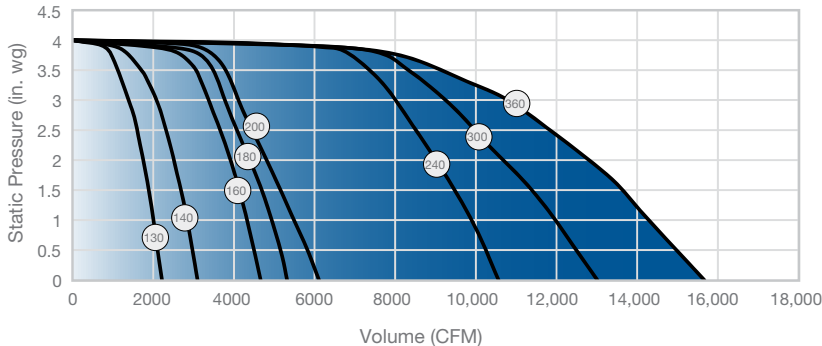

○ Fan Size

Performance certified is for installation type B: free inlet, ducted outlet. Performance ratings do not include the effects of appurtenances (accessories).

MODEL GB

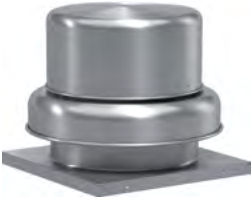

- Belt Drive Centrifugal Downblast Fans
- Backward inclined centrifugal wheel
- NEMA-1 disconnect
- Aluminum construction on fan shroud, curb cap
- Galvanized birdscreen
- ODP motor
- 115/1 voltage

	Sizes	HP	Curb Cap
GB-098*	825 CFM @ 0.1 SP	¼ HP	19 × 19
GB-099*	1,200 CFM @ 0.1 SP	¼ HP	19 × 19
GB-100*	1,350 CFM @ 0.1 SP	¼ HP	19 × 19
GB-120*	1,700 CFM @ 0.1 SP	¼ HP	19 × 19
GB-140**	2,400 CFM @ 0.1 SP	½ HP	22 × 22

*OPTIONAL MODEL BD-100 12 × 12, ** OPTIONAL DAMPER BD-100 16 × 16

MODEL G-VG

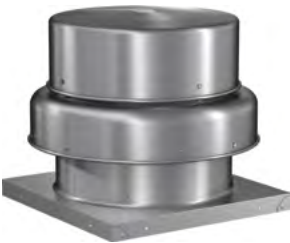

- Direct Drive Centrifugal Downblast Fans
- Backward inclined centrifugal wheel
- NEMA-1 disconnect
- Aluminum construction on fan shroud, curb cap
- Galvanized birdscreen
- ODP motor (EC motor on G-100-VG model)
- 115/1 voltage

	Sizes	HP	Curb Cap
G-080*	445 CFM @ 0.1 SP	½0 HP	17 × 17
G-090*	710 CFM @ 0.1 SP	1/15 HP	17 × 17
G-095*	980 CFM @ 0.1 SP	⅙ HP	17 × 17
G-100-VG	477 -1462 @ 0.1 SP	¼ HP	19 × 19

*OPTIONAL MODEL BD-100 10 × 10 DAMPER, 6AMP SPEED CONTROLLER

Roof Downblast Exhaust Size-060: G

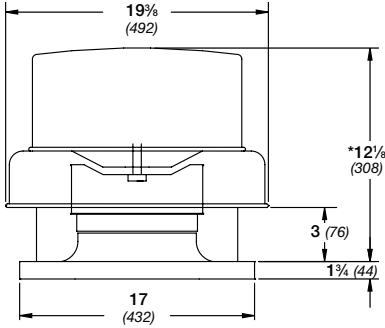

Damper Size = 8 x 8 (203 x 203)
 Roof Opening = 13 1/2 x 13 1/2 (343 x 343)
 Shroud Thickness = 0.064 (1.6)
 Motor Cover Thickness = 0.040 (1.0)
 Curb Cap Thickness = 0.064 (1.6)
 ^Approximate Unit Weight = 15 lbs. (7 kg)

All dimensions in inches (millimeters). *May be greater depending on motor.
 ^Weight shown is largest cataloged Open Drip-Proof motor.

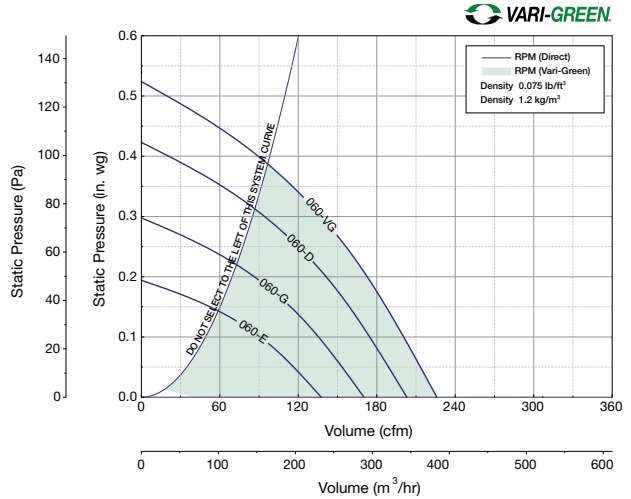

Direct Drive RPM

E-1050 RPM G-1300 RPM D-1550 RPM VG-1725 RPM

Direct Drive	Motor HP	Fan RPM		Static Pressure in Inches wg													
				0	0.05	0.1	0.125	0.15	0.2	0.25	0.3	0.375	0.4				
060																	
VARI-GREEN	E-1/200	1050	CFM	138	116	90	73	53									
			BHP	0.00	0.00	0.01	0.01	0.01									
			Sones	1.7	1.7	1.7	1.7	1.7									
	G-1/100	1300	CFM	170	153	135	125	113	85								
			BHP	0.01	0.01	0.01	0.01	0.01	0.01								
			Sones	2.9	2.8	2.8	2.7	2.7	2.6								
	D-1/60	1550	CFM	203	188	173	166	158	140	120	92						
			BHP	0.01	0.01	0.01	0.01	0.02	0.02	0.02	0.02	0.02					
			Sones	4.3	3.9	3.8	3.8	3.8	3.7	3.7	3.6						
		1725	CFM	226	213	199	193	186	173	155	137	101	89				
			BHP	0.02	0.02	0.02	0.02	0.02	0.02	0.02	0.02	0.02	0.02	0.02			
			Sones	5.4	4.9	4.9	4.8	4.8	4.8	4.7	4.6	4.5	4.4				

Performance certified is for installation type A: Free inlet, Free outlet. Power rating (BHP) does not include transmission losses. Performance ratings include the effects of a birdscreen. The sound ratings shown are loudness values in hemispherical zones at 5 ft (1.5 m) in a hemispherical free field calculated per AMCA Standard 301

Roof Downblast Exhaust Size-070: G

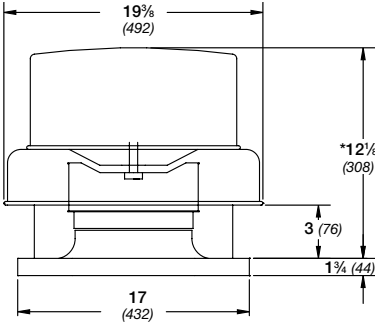

Damper Size = 8 x 8 (203 x 203)
 Roof Opening = 13 1/2 x 13 1/2 (343 x 343)
 Shroud Thickness = 0.064 (1.6)
 Motor Cover Thickness = 0.040 (1.0)
 Curb Cap Thickness = 0.064 (1.6)
 ^Approximate Unit Weight = 15 lbs. (7 kg)

All dimensions in inches (millimeters). *May be greater depending on motor.
 ^Weight shown is largest cataloged Open Drip-Proof motor.

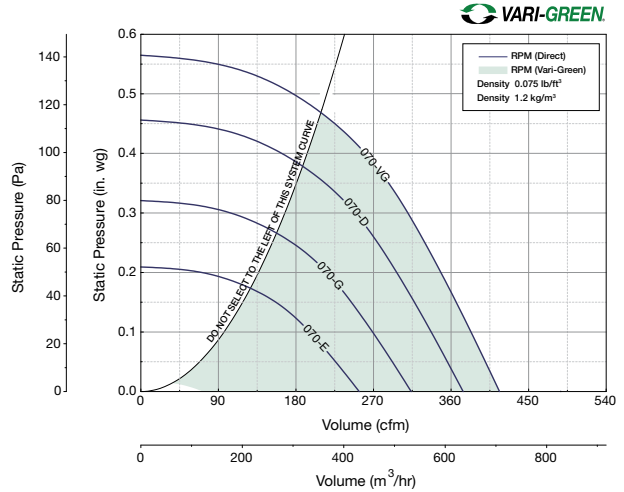

Direct Drive RPM

E-1050 RPM	G-1300 RPM	D-1550 RPM	VG-1725 RPM
------------	------------	------------	-------------

Direct Drive	Motor HP	Fan RPM	Static Pressure in Inches wg										
			0	0.05	0.1	0.125	0.15	0.2	0.25	0.3	0.375	0.4	
070													
VARI-GREEN	E-1/100	1050	CFM	253	226	195	179	152					
			BHP	0.01	0.01	0.01	0.01	0.01					
		Sones	2.7	2.1	1.7	1.5	1.2						
		1300	CFM	314	292	269	257	244	214	171			
			BHP	0.01	0.01	0.02	0.02	0.02	0.02	0.02			
		Sones	4.1	3.7	3.4	3.3	3.2	2.9	2.6				
	D-1/30	1550	CFM	374	356	337	327	317	297	274	244	190	
			BHP	0.02	0.02	0.02	0.03	0.03	0.03	0.03	0.03	0.03	0.03
		Sones	5.6	5.4	5.2	5.1	5.1	4.9	4.7	4.5	4.1		
		1725	CFM	416	400	383	375	366	348	329	309	270	253
			BHP	0.03	0.03	0.03	0.03	0.03	0.04	0.04	0.04	0.04	0.04
		Sones	6.8	6.7	6.7	6.6	6.6	6.5	6.3	6.2	5.9	5.7	

Performance certified is for installation type A: Free inlet, Free outlet. Power rating (BHP) does not include transmission losses. Performance ratings include the effects of a birdscreen. The sound ratings shown are loudness values in hemispherical sones at 5 ft. (1.5 m) in a hemispherical free field calculated per AMCA Standard 301. Values shown are for installation type A: free inlet hemispherical sone levels.

FANS - PERFORMANCE



Roof Downblast Exhaust Size-080: G

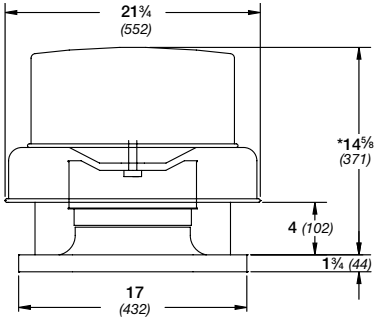

Damper Size = 10 x 10 (254 x 254)
 Roof Opening = 13 1/2 x 13 1/2 (343 x 343)
 Shroud Thickness = 0.064 (1.6)
 Motor Cover Thickness = 0.040 (1.0)
 Curb Cap Thickness = 0.064 (1.6)
 *Approximate Unit Weight = 19 lbs. (9 kg)

All dimensions in inches (millimeters). *May be greater depending on motor.
 *Weight shown is largest cataloged Open Drip-Proof motor.

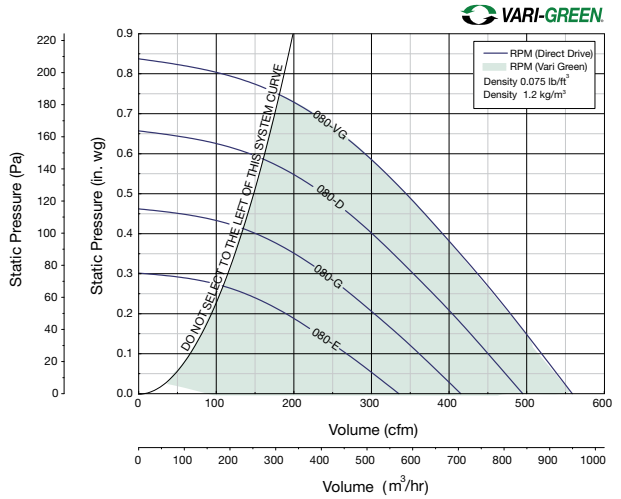

Direct Drive RPM			
E-1050 RPM	G-1300 RPM	D-1550 RPM	VG-1725 RPM

Direct Drive	Motor HP	Fan RPM	Static Pressure in Inches wg										
			0	0.1	0.125	0.15	0.2	0.25	0.3	0.375	0.5	0.625	
080													
VARI-GREEN	E-1/40	1050	CFM	335	268	249	230	189	134				
			BHP	0.01	0.02	0.02	0.02	0.02	0.02				
			Sones	3.8	3.7	3.6	3.7	3.9	4.2				
	G-1/30	1300	CFM	415	361	348	333	303	272	239	174		
			BHP	0.02	0.03	0.03	0.03	0.03	0.03	0.03	0.03		
			Sones	5.4	5.4	5.4	5.4	5.4	5.5	5.6	5.9		
	D-1/20	1550	CFM	495	450	439	427	404	379	354	314	237	
			BHP	0.04	0.04	0.04	0.05	0.05	0.05	0.05	0.06	0.06	
			Sones	7.3	7.3	7.3	7.3	7.3	7.2	7.3	7.3	7.6	
		1725	CFM	551	511	501	490	469	449	426	392	332	260
			BHP	0.05	0.06	0.06	0.06	0.06	0.07	0.07	0.07	0.08	0.08
			Sones	9.1	9.1	9.1	9.1	9	8.9	8.9	8.9	9.1	9.4

Performance certified is for installation type A: Free inlet, Free outlet. Power rating (BHP) does not include transmission losses. Performance ratings include the effects of a birdscreen. The sound ratings shown are loudness values in hemispherical sones at 5 ft. (1.5 m) in a hemispherical free field calculated per AMCA Standard 301. Values shown are for installation type A: free inlet hemispherical sone levels.

Roof Downblast Exhaust Sizes-090 • 095: G

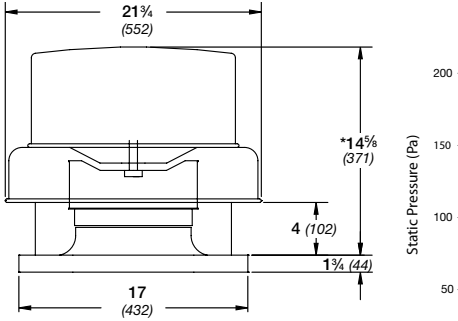

- Damper Size = 10 x 10 (254 x 254)
- Roof Opening = 13 1/2 x 13 1/2 (343 x 343)
- Shroud Thickness = 0.064 (1.6)
- Motor Cover Thickness = 0.040 (1.0)
- Curb Cap Thickness = 0.064 (1.6)
- ^Approximate Unit Weight = 22 lbs. (10 kg)

All dimensions in inches (millimeters). *May be greater depending on motor.
^Weight shown is largest cataloged Open Drip-Proof motor.

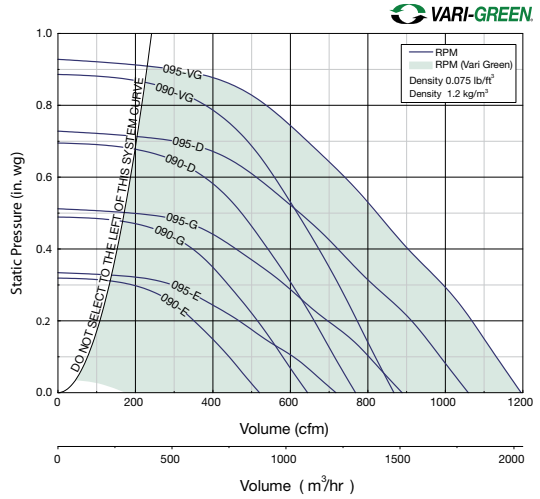

Direct Drive RPM

- E-1050 RPM
- G-1300 RPM
- D-1550 RPM
- VG-1725 RPM

Direct Drive	Motor HP	Fan RPM	Static Pressure in Inches wg										
			0	0.1	0.125	0.15	0.2	0.25	0.3	0.375	0.5	0.625	
090													
VARI-GREEN	E-1/40	1050	CFM	520	441	420	398	351	293				
			BHP	0.01	0.02	0.02	0.02	0.02	0.02				
			Sones	4	3.9	3.9	4	4.1	4.2				
	G-1/25	1300	CFM	644	580	565	549	515	478	440	373		
			BHP	0.03	0.03	0.04	0.04	0.04	0.04	0.04	0.05		
			Sones	5.4	5.4	5.4	5.4	5.4	5.5	5.5	5.6		
	D-1/15	1550	CFM	768	714	701	688	662	633	605	557	473	338
			BHP	0.05	0.05	0.06	0.06	0.06	0.06	0.07	0.07	0.08	0.07
			Sones	7.6	7.5	7.5	7.5	7.5	7.4	7.4	7.4	7.4	7.8
		1725	CFM	855	806	794	782	759	735	709	671	600	522
			BHP	0.06	0.07	0.07	0.08	0.08	0.08	0.09	0.09	0.10	0.11
			Sones	9.7	9.5	9.5	9.5	9.5	9.4	9.4	9.2	9.1	9.1
095													
VARI-GREEN	E-1/30	1050	CFM	717	606	570	534	468	389	290			
			BHP	0.03	0.03	0.04	0.04	0.04	0.04	0.03			
			Sones	5.4	4.5	4.5	4.5	4.4	4.5	4.6			
	G-1/12	1300	CFM	888	802	780	754	695	640	586	493	184	
			BHP	0.06	0.06	0.06	0.06	0.07	0.07	0.07	0.07	0.05	
			Sones	7.6	6.8	6.7	6.6	6.5	6.4	6.4	6.4	6.8	
	D-1/8	1550	CFM	1059	987	969	950	912	863	814	745	623	474
			BHP	0.10	0.10	0.10	0.11	0.11	0.11	0.11	0.12	0.12	0.11
			Sones	9.6	9.4	9.3	9.2	9	8.8	8.7	8.7	8.7	8.7
		1725	CFM	1179	1114	1098	1081	1048	1013	969	903	800	688
			BHP	0.13	0.14	0.14	0.14	0.15	0.15	0.15	0.16	0.16	0.16
			Sones	11.4	11.4	11.4	11.5	11.4	11.2	11	10.9	11.3	11.3

Performance certified is for installation type A: Free inlet, Free outlet. Power rating (BHP) does not include transmission losses. Performance ratings include the effects of a birdscreen. The sound ratings shown are loudness values in hemispherical sones at 5 ft. (1.5 m) in a hemispherical free field calculated per AMCA Standard 301. Values shown are for installation type A: Free inlet hemispherical sone levels.

FANS - PERFORMANCE



Roof Downblast Exhaust Size-098: GB • G Previously Size- GB-081

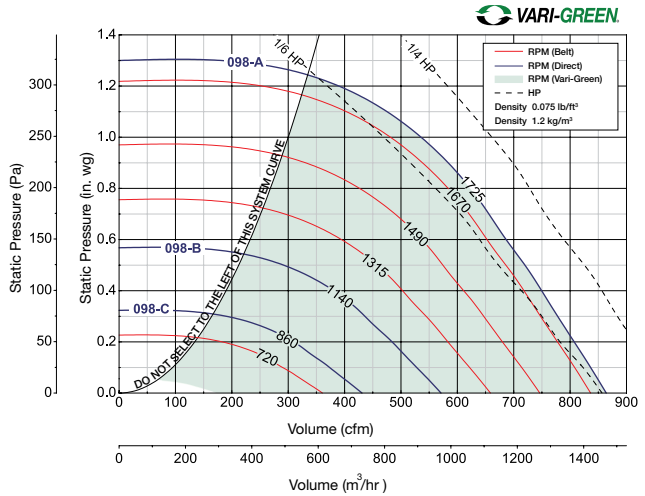
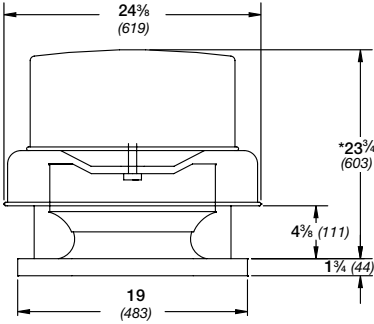

Damper Size = 12 x 12 (305 x 305)
 Roof Opening = 15 1/2 x 15 1/2 (394 x 394)
 Shroud Thickness = 0.051 (1.3)
 Motor Cover Thickness = 0.040 (1.0)
 Curb Cap Thickness = 0.064 (1.6)
 ^Approximate Unit Weight G/GB = 54/60 lbs. (24/27 kg)

All dimensions in inches (millimeters). *May be greater depending on motor. ^Weight shown is largest cataloged Open Drip-Proof motor.

Direct Drive RPM
 C-860 RPM B-1140 RPM A-1725 RPM VG-1725 RPM

Motor HP		Fan RPM	Static Pressure in Inches wg										
Belt	Direct		0	0.125	0.25	0.375	0.5	0.625	0.75	0.875	1	1.125	
098													
1/6	VG-1/4	720	CFM	361	272								
			BHP	0.01	0.01								
			Sones	3.0	2.7								
		790	CFM	396	315	181							
			BHP	0.02	0.02	0.02							
			Sones	3.5	3.2	3							
	C-1/8	860	CFM	431	358	261							
			BHP	0.02	0.02	0.02							
			Sones	4.0	3.7	3.4							
		930	CFM	466	399	323							
			BHP	0.03	0.03	0.03							
			Sones	4.6	4.4	4.0							
	B-1/6	1000	CFM	501	439	372	259						
			BHP	0.03	0.04	0.04	0.04						
			Sones	5.3	5.1	4.7	4.4						
		1070	CFM	536	478	416	338						
			BHP	0.04	0.04	0.05	0.05						
			Sones	5.9	5.8	5.4	5.0						
A-1/4	1140	CFM	571	517	460	396	283						
		BHP	0.05	0.05	0.06	0.06	0.05						
		Sones	6.6	6.5	6.1	5.7	5.5						
	1315	CFM	659	612	564	513	456	362					
		BHP	0.08	0.08	0.08	0.09	0.09	0.08					
		Sones	8.3	8.1	7.8	7.4	7.0	6.9					
1490	CFM	746	706	663	621	574	525	452	353				
	BHP	0.11	0.12	0.12	0.12	0.12	0.12	0.12	0.11				
	Sones	10.1	9.9	9.8	9.3	8.9	8.6	8.5	8.4				
1670	CFM	836	800	763	725	686	645	603	550	466	377		
	BHP	0.16	0.16	0.16	0.17	0.17	0.17	0.17	0.18	0.17	0.16		
	Sones	12.0	11.9	11.7	11.4	11.0	10.7	10.4	10.1	10.0	9.9		
1/4	A-1/4	1725	CFM	864	829	793	756	719	679	640	592	527	441
			BHP	0.17	0.18	0.18	0.18	0.19	0.19	0.19	0.19	0.19	0.18
			Sones	12.7	12.5	12.3	12.1	11.7	11.4	11.1	10.8	10.6	10.5

MAXIMUM BHP AT A GIVEN RPM = (RPM/2985)³
 MAXIMUM RPM = 1725
 TIP SPEED (ft/min) = RPM x 2.929
 MAXIMUM MOTOR FRAME SIZE = 56

Performance certified is for installation type A: Free inlet, Free outlet. Power rating (BHP) does not include transmission losses. Performance ratings include the effects of a birdscreen. The sound ratings shown are loudness values in hemispherical sones at 5 ft. (1.5 m) in a hemispherical free field calculated per AMCA Standard 301. Values shown are for installation type A: free inlet hemispherical sone levels.

FANS - PERFORMANCE



Roof Downblast Exhaust Size-099: GB • G Previously Size- GB-091

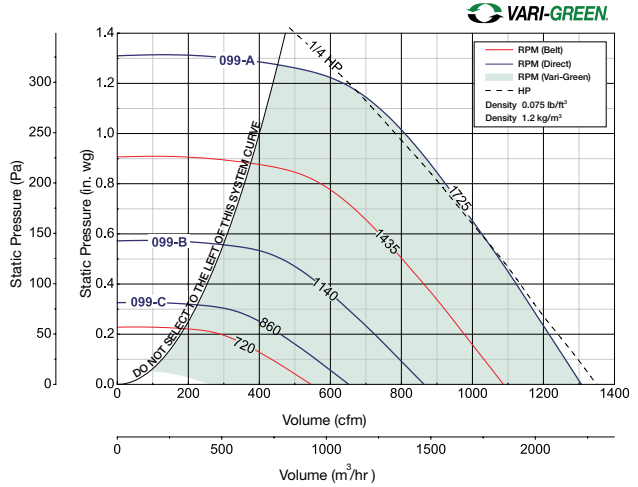
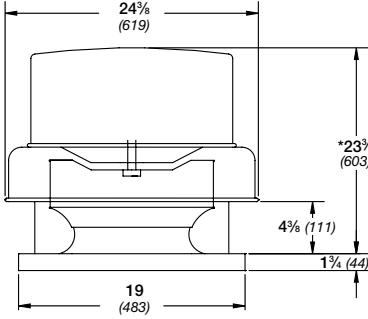

Damper Size = 12 x 12 (305 x 305)
 Roof Opening = 15 1/2 x 15 1/2 (394 x 394)
 Shroud Thickness = 0.051 (1.3)
 Motor Cover Thickness = 0.040 (1.0)
 Curb Cap Thickness = 0.064 (1.6)
 ^Approximate Unit Weight G/GB = 54/61 lbs. (24/28 kg)

All dimensions in inches (millimeters). *May be greater depending on motor. ^Weight shown is largest cataloged Open Drip-Proof motor.

Direct Drive RPM
 C-860 RPM B-1140 RPM A-1725 RPM VG-1725 RPM

Motor HP		Fan RPM	Static Pressure in Inches wg										
Belt	Direct		0	0.125	0.25	0.375	0.5	0.625	0.75	0.875	1	1.125	
099													
1/4	VARI-GREEN VG-1/4	720	CFM	546	403								
			BHP	0.02	0.02								
		Sones	3.6	3.5									
		790	CFM	599	471	291							
			BHP	0.02	0.02	0.02							
		Sones	4.2	4.1	3.9								
		C-1/8	860	CFM	652	536	400						
				BHP	0.03	0.03	0.03						
		Sones	4.9	4.7	4.5								
		1000	1140	CFM	705	598	481						
	BHP			0.04	0.04	0.04							
	Sones	5.6	5.5	5.1									
	1070	1435	CFM	758	659	552	414						
			BHP	0.04	0.05	0.05	0.05						
	Sones	6.4	6.2	5.8	5.6								
	B-1/6	1725	CFM	811	718	621	512						
			BHP	0.05	0.06	0.06	0.06						
	Sones	7.3	7.1	6.7	6.3								
	1285	1435	CFM	864	777	687	590	457					
			BHP	0.07	0.07	0.07	0.07	0.07					
Sones	8.3	8.1	7.6	7.1	6.8								
1435	1580	CFM	974	897	819	736	647	526					
		BHP	0.09	0.10	0.10	0.10	0.11	0.10					
Sones	9.5	9.4	9.0	8.5	8.2	7.9							
1580	1725	CFM	1087	1018	949	877	801	721	615	404			
		BHP	0.13	0.14	0.14	0.14	0.15	0.15	0.15	0.12			
Sones	10.7	10.6	10.4	10.0	9.6	9.3	9.0	8.4					
A-1/4	1725	CFM	1197	1135	1072	1009	941	872	799	707	583		
		BHP	0.17	0.18	0.19	0.19	0.19	0.20	0.20	0.20	0.19		
Sones	12.1	12.0	11.9	11.5	11.2	10.9	10.6	10.3	9.8				
		CFM	1307	1250	1192	1135	1076	1013	949	883	806	707	
		BHP	0.23	0.23	0.24	0.24	0.25	0.25	0.26	0.26	0.26	0.25	
		Sones	13.6	13.5	13.4	13.2	12.9	12.6	12.3	12.0	11.8	11.5	

MAXIMUM BHP AT A GIVEN RPM = (RPM/2703)³
 MAXIMUM RPM = 1725
 TIP SPEED (ft/min) = RPM x 2.929
 MAXIMUM MOTOR FRAME SIZE = 56

Performance certified is for installation type A: Free inlet, Free outlet. Power rating (BHP) does not include transmission losses. Performance ratings include the effects of a birdscreen. The sound ratings shown are loudness values in hemispherical sones at 5 ft. (1.5 m) in a hemispherical free field calculated per AMCA Standard 301. Values shown are for installation type A: free inlet hemispherical sone levels.

FANS - PERFORMANCE



Roof Downblast Exhaust
Size-100: GB • G
 Previously Size- GB-101 • G-103

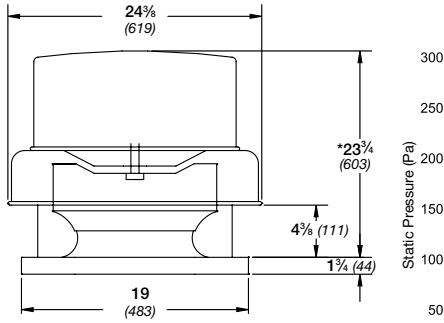

Damper Size = 12 x 12 (305 x 305)
 Roof Opening = 15 1/2 x 15 1/2 (394 x 394)
 Shroud Thickness = 0.051 (1.3)
 Motor Cover Thickness = 0.040 (1.0)
 Curb Cap Thickness = 0.064 (1.6)
 ^Approximate Unit Weight G/GB = 54/61 lbs. (24/28 kg)

All dimensions in inches (millimeters). *May be greater depending on motor. ^Weight shown is largest cataloged Open Drip-Proof motor.

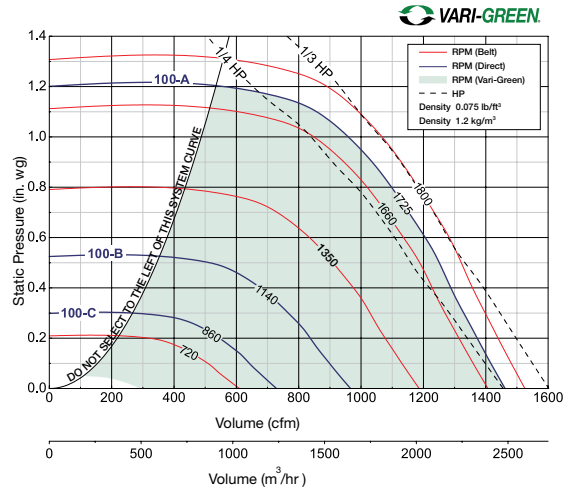

Direct Drive RPM

C-860 RPM B-1140 RPM A-1725 RPM VG-1725 RPM

Motor HP	Fan RPM	Static Pressure in Inches wg																					
		0	0.125	0.25	0.375	0.5	0.625	0.75	0.875	1	1.25												
100	VG-1/4	C-1/8	720	CFM 610	477																		
			BHP 0.02	0.02																			
			Sones 3.8	2.7																			
		860	CFM 729	623	473																		
		BHP 0.03	0.04	0.04																			
		Sones 4.6	3.7	2.9																			
	1000	CFM 848	753	654	481																		
	BHP 0.05	0.05	0.06	0.05																			
	Sones 5.5	4.8	4.4	3.4																			
	B-1/6	1140	CFM 966	883	805	702	507																
		BHP 0.07	0.08	0.09	0.09	0.08																	
		Sones 6.6	6.0	5.7	5.2	4.1																	
1245		CFM 1055	978	908	824	715																	
BHP 0.10		0.10	0.11	0.11	0.11																		
Sones 7.5		7.0	6.7	6.3	5.7																		
1350	CFM 1144	1073	1006	938	851	731																	
BHP 0.12	0.13	0.13	0.14	0.14	0.14																		
Sones 8.5	8.1	7.8	7.7	7.2	6.7																		
1450	CFM 1229	1162	1099	1041	965	878	750																
BHP 0.15	0.16	0.16	0.17	0.17	0.17	0.17																	
Sones 9.3	9.0	8.7	8.4	8.0	7.5	6.9																	
1555	CFM 1318	1255	1196	1140	1079	1005	917	791															
BHP 0.19	0.19	0.20	0.21	0.22	0.22	0.22	0.22	0.21															
Sones 10.2	10.0	9.7	9.4	8.9	8.4	8.0	7.5	6.9															
1660	CFM 1407	1348	1292	1238	1187	1122	1050	963	841														
BHP 0.23	0.23	0.24	0.25	0.26	0.26	0.26	0.26	0.26	0.25														
Sones 11.4	11.1	10.7	10.4	10.1	9.6	9.1	8.7	8.1															
1/3	A-1/4	1725	CFM 1462	1405	1351	1298	1250	1193	1126	1052	955												
		BHP 0.25	0.26	0.27	0.28	0.29	0.29	0.29	0.29	0.29	0.29												
		Sones 12.2	11.9	11.5	11.2	10.9	10.3	10.0	9.5	9.0													
	1800	CFM 1525	1471	1419	1368	1321	1270	1209	1142	1065	793												
	BHP 0.29	0.30	0.30	0.31	0.33	0.33	0.33	0.33	0.33	0.33	0.33												
	Sones 13.3	12.8	12.5	12.4	12.2	11.4	10.9	10.6	10.2	9.3													

MAXIMUM BHP AT A GIVEN RPM = (RPM/2593)³
 MAXIMUM RPM = 1800
 TIP SPEED (ft/min) = RPM x 2.913
 MAXIMUM MOTOR FRAME SIZE = 56

Performance certified is for installation type A: Free inlet, Free outlet. Power rating (BHP) does not include transmission losses. Performance ratings include the effects of a birdscreen. The sound ratings shown are loudness values in hemispherical sones at 5 ft. (1.5 m) in a hemispherical free field calculated per AMCA Standard 301. Values shown are for installation type A: free inlet hemispherical sone levels.

FANS - PERFORMANCE



Roof Downblast Exhaust

Size-100HP: GB • G

Previously Size- GB-101HP • G-103HP

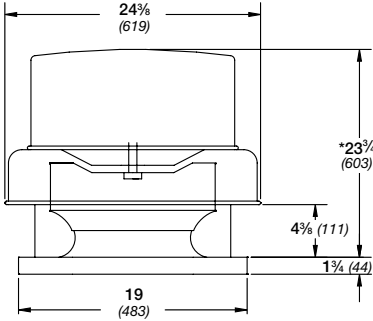

Damper Size = 12 x 12 (305 x 305)
 Roof Opening = 15 1/2 x 15 1/2 (394 x 394)
 Shroud Thickness = 0.051 (1.3)
 Motor Cover Thickness = 0.040 (1.0)
 Curb Cap Thickness = 0.064 (1.6)
 *Approximate Unit Weight G/GB = 58/63 lbs. (26/29 kg)

All dimensions in inches (millimeters). *May be greater depending on motor. *Weight shown is largest cataloged Open Drip-Proof motor.

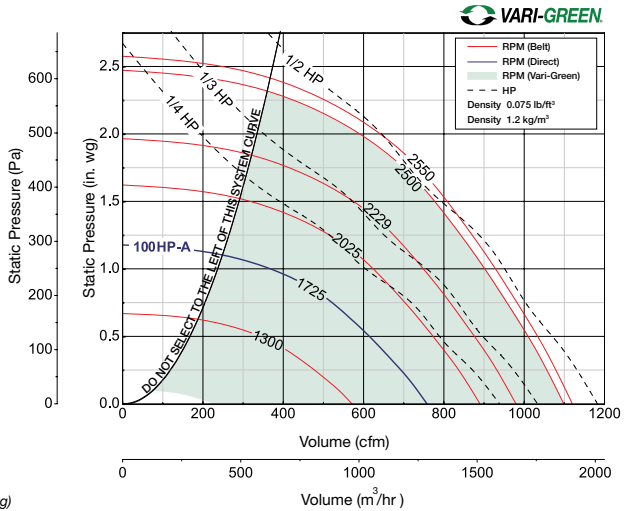

Direct Drive RPM
 A-1725 RPM VG-2550 RPM

Motor HP		Fan RPM	Static Pressure in Inches wg										
Belt	Direct		0	0.25	0.5	0.75	1	1.25	1.5	1.75	2	2.25	
100HP													
1/4	VG-1/4	1300	CFM	571	477	342							
			BHP	0.06	0.06	0.07							
			Sones	6.6	5.7	5.3							
		1445	CFM	635	553	449	243						
			BHP	0.08	0.09	0.09	0.08						
			Sones	8.4	7.5	7	6.3						
	A-1/4	1590	CFM	699	626	537	417						
			BHP	0.10	0.11	0.12	0.12						
			Sones	10.4	9.5	9.1	8.3						
		1725	CFM	758	692	613	521	364					
			BHP	0.13	0.14	0.15	0.16	0.15					
			Sones	11.4	10.7	10.6	10.1	10					
1/3	VG-1/2	1880	CFM	826	767	697	618	518	337				
			BHP	0.17	0.18	0.19	0.20	0.20	0.18				
			Sones	12.7	12.2	11.9	12	11.4	11.9				
		2025	CFM	890	836	772	702	622	515	313			
			BHP	0.21	0.23	0.24	0.24	0.26	0.25	0.22			
			Sones	14.2	13.6	13.3	13.2	12.6	12	11.4			
	VARI-GREEN	2137	CFM	939	889	830	765	693	607	474			
			BHP	0.25	0.26	0.28	0.28	0.29	0.30	0.28			
			Sones	15.4	14.8	14.4	14.2	13.4	13.1	12.1			
		2229	CFM	979	931	875	814	748	674	574	406		
			BHP	0.28	0.30	0.31	0.32	0.33	0.35	0.33	0.31		
			Sones	15.8	15.4	14.8	14.5	14.1	13.7	13.2	12.0		
1/2	VARI-GREEN	2336	CFM	1026	981	928	871	809	742	661	543	358	
			BHP	0.33	0.34	0.36	0.36	0.37	0.39	0.40	0.37	0.34	
			Sones	16.4	16	15.4	14.9	14.7	14	14.1	13.5	13.6	
		2500	CFM	1098	1056	1008	956	901	840	775	695	583	416
			BHP	0.40	0.42	0.43	0.45	0.45	0.46	0.48	0.48	0.46	0.42
			Sones	17.8	17.4	16.9	16.7	15.8	15.5	14.8	15.2	15.7	16.6
	2550	CFM	1120	1078	1032	982	928	869	807	735	639	497	
		BHP	0.43	0.44	0.46	0.47	0.47	0.49	0.51	0.52	0.50	0.47	
		Sones	18.2	17.9	17.4	17.2	16.3	16.1	15.1	15.6	16.2	17.2	

MAXIMUM BHP AT A GIVEN RPM = (RPM/3165)³
 MAXIMUM RPM = 2550
 TIP SPEED (ft/min) = RPM x 2.978
 MAXIMUM MOTOR FRAME SIZE = 56

Performance certified is for installation type A: Free inlet, Free outlet. Power rating (BHP) does not include transmission losses. Performance ratings include the effects of a birdscreen. The sound ratings shown are loudness values in hemispherical sones at 5 ft. (1.5 m) in a hemispherical free field calculated per AMCA Standard 301. Values shown are for installation type A: free inlet hemispherical sone levels.

FANS - PERFORMANCE



Roof Downblast Exhaust Size-120: GB • G Previously Size- GB-121 • G-123

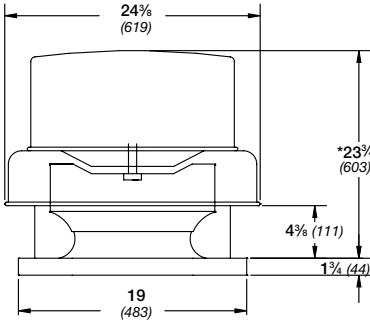

Damper Size = 12 x 12 (305 x 305)
 Roof Opening = 15 1/2 x 15 1/2 (394 x 394)
 Shroud Thickness = 0.051 (1.3)
 Motor Cover Thickness = 0.040 (1.0)
 Curb Cap Thickness = 0.064 (1.6)
 ^Approximate Unit Weight G/GB = 58/66 lbs. (26/30 kg)

All dimensions in inches (millimeters). *May be greater depending on motor. ^Weight shown is largest cataloged Open Drip-Proof motor.

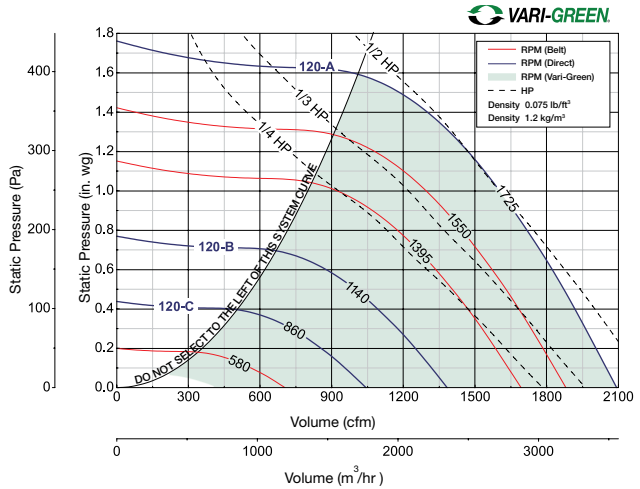

Direct Drive RPM

C-860 RPM B-1140 RPM A-1725 RPM VG-1725 RPM

Motor HP		Fan RPM	Static Pressure in Inches wg										
Belt	Direct		0	0.125	0.25	0.375	0.5	0.625	0.75	1	1.25	1.5	
120													
1/4	VARI-GREEN VG-1/4	580	CFM	704	515								
			BHP	0.02	0.02								
			Sones	3.2	3.3								
		720	CFM	873	735	523							
			BHP	0.03	0.04	0.04							
			Sones	4.2	4.3	4.1							
	VARI-GREEN VG-1/2	C-1/8	860	CFM	1043	932	796	580					
				BHP	0.05	0.06	0.06	0.06					
				Sones	5.4	5.5	5.2	5.2					
		B-1/6	1000	CFM	1213	1119	1013	883	694				
				BHP	0.08	0.09	0.09	0.10	0.09				
				Sones	6.7	6.8	6.7	6.4	6.4				
1140	CFM	1383	1300	1213	1112	993	831						
	BHP	0.12	0.13	0.14	0.14	0.14	0.14						
	Sones	8.4	8.4	8.4	8.1	7.9	7.8						
1/3	VARI-GREEN VG-1/2	1265	CFM	1535	1460	1384	1299	1204	1093	950			
			BHP	0.16	0.17	0.18	0.19	0.19	0.20	0.19			
			Sones	10.2	10.1	10.1	9.9	9.7	9.6	9.4			
		1395	CFM	1692	1625	1557	1484	1404	1315	1214	907		
			BHP	0.21	0.23	0.24	0.25	0.26	0.26	0.26	0.24		
			Sones	12.5	12.4	12.3	12.2	12.0	11.7	11.5	11.3		
	VARI-GREEN VG-1/2	1475	CFM	1789	1726	1661	1594	1521	1441	1356	1132		
			BHP	0.25	0.27	0.28	0.29	0.30	0.31	0.31	0.31		
			Sones	13.5	13.4	13.3	13.2	13.0	12.7	12.4	12.0		
		1550	CFM	1880	1820	1759	1696	1629	1555	1475	1289	974	
			BHP	0.29	0.31	0.32	0.33	0.34	0.35	0.36	0.36	0.33	
			Sones	14.6	14.5	14.3	14.2	14.0	13.8	13.5	12.9	12.4	
1/2	A-1/2	1635	CFM	1983	1926	1868	1810	1747	1680	1608	1446	1231	
			BHP	0.34	0.36	0.37	0.39	0.40	0.41	0.42	0.43	0.41	
			Sones	15.9	15.8	15.6	15.4	15.3	15.0	14.8	13.9	13.4	
	1725	CFM	2093	2038	1984	1928	1871	1810	1743	1600	1426	1180	
		BHP	0.40	0.42	0.44	0.45	0.46	0.47	0.48	0.50	0.50	0.47	
		Sones	17.4	17.2	17.0	16.8	16.7	16.4	16.2	15.5	14.9	14.0	

MAXIMUM BHP AT A GIVEN RPM = (RPM/2170)³
 MAXIMUM RPM = 1725
 TIP SPEED (ft/min) = RPM x 3.420
 MAXIMUM MOTOR FRAME SIZE = 56

Performance certified is for installation type A: Free inlet, Free outlet. Power rating (BHP) does not include transmission losses. Performance ratings include the effects of a birdscreen. The sound ratings shown are loudness values in hemispherical sones at 5 ft. (1.5 m) in a hemispherical free field calculated per AMCA Standard 301. Values shown are for installation type A: free inlet hemispherical sone levels.

FANS - PERFORMANCE



Roof Downblast Exhaust Size-130: GB • G Previously Size- GB-131 • G-133

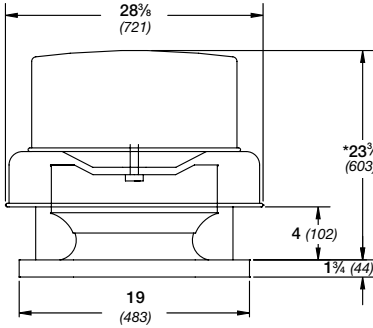

Damper Size = 12 x 12 (305 x 305)
 Roof Opening = 15 1/2 x 15 1/2 (394 x 394)
 Shroud Thickness = 0.051 (1.3)
 Motor Cover Thickness = 0.040 (1.0)
 Curb Cap Thickness = 0.064 (1.6)
 ^Approximate Unit Weight G/GB = 62/67 lbs. (28/30 kg)

All dimensions in inches (millimeters). *May be greater depending on motor. ^Weight shown is largest cataloged Open Drip-Proof motor.

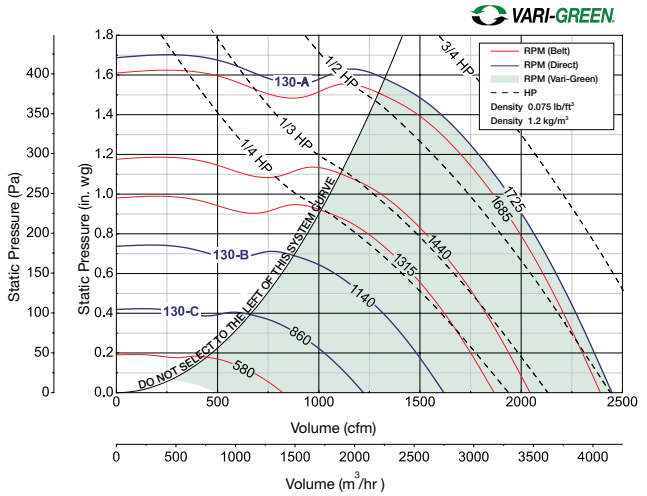

Direct Drive RPM

C-860 RPM B-1140 RPM A-1725 RPM VG-1725 RPM

Motor HP		Fan RPM	Static Pressure in Inches wg									
Belt	Direct		0	0.125	0.25	0.375	0.5	0.625	0.75	1	1.25	1.5
130												
1/4	VG-1/4	580	CFM	823	626							
			BHP	0.02	0.02							
			Sones	4.5	4.5							
		720	CFM	1022	879	650						
			BHP	0.04	0.04	0.04						
			Sones	5.4	5.4	5.2						
	C-1/8	860	CFM	1221	1106	962	727					
			BHP	0.06	0.07	0.07	0.07					
			Sones	6.6	6.5	6.3	6.0					
		1000	CFM	1419	1323	1213	1075	867				
			BHP	0.10	0.11	0.11	0.12	0.11				
			Sones	8.1	8.0	7.7	7.4	7.0				
B-1/6	1140	CFM	1618	1535	1444	1340	1211	1031				
		BHP	0.15	0.16	0.16	0.17	0.17	0.17				
		Sones	10.0	9.8	9.6	9.2	8.8	8.5				
	1250	CFM	1774	1698	1617	1528	1426	1133				
		BHP	0.19	0.2	0.21	0.22	0.23	0.22				
		Sones	12.0	11.7	11.3	11.0	10.5	9.7				
VG-1/2	1315	CFM	1866	1794	1718	1637	1545	1435	1305			
		BHP	0.22	0.23	0.24	0.25	0.26	0.26	0.26			
		Sones	13.2	12.8	12.5	12.1	11.7	11.2	10.9			
	1440	CFM	2044	1978	1911	1838	1759	1674	1571	1299		
		BHP	0.29	0.31	0.32	0.33	0.34	0.34	0.35	0.34		
		Sones	15.0	15.0	15.1	15.1	14.5	13.9	13.4	12.5		
1/3	1600	CFM	2271	2212	2152	2088	2023	1873	1783	1686	1425	
		BHP	0.40	0.42	0.43	0.44	0.45	0.47	0.47	0.48	0.47	
		Sones	16.2	16.0	15.8	15.6	15.3	14.6	14.2	13.9	13.2	
	1685	CFM	2391	2335	2279	2219	2158	2093	2020	1857	1654	1312
		BHP	0.47	0.48	0.50	0.51	0.52	0.54	0.55	0.56	0.56	0.52
		Sones	16.9	16.6	16.3	16.0	15.7	15.1	14.8	14.5	13.9	13.5
3/4	A-1/2	CFM	2448	2393	2338	2281	2220	2159	2089	1935	1746	1474
		BHP	0.50	0.52	0.53	0.55	0.56	0.57	0.58	0.59	0.60	0.58
		Sones	17.4	17.0	16.7	16.3	15.9	15.6	15.4	14.9	14.3	13.8

MAXIMUM BHP AT A GIVEN RPM = (RPM/2047)³
 MAXIMUM RPM = 1725
 TIP SPEED (ft/min) = RPM x 3.436
 MAXIMUM MOTOR FRAME SIZE = 56

Performance certified is for installation type A: Free inlet, Free outlet. Power rating (BHP) does not include transmission losses. Performance ratings include the effects of a birdscreen. The sound ratings shown are loudness values in hemispherical sones at 5 ft. (1.5 m) in a hemispherical free field calculated per AMCA Standard 301. Values shown are for installation type A: free inlet hemispherical sone levels.

FANS - PERFORMANCE



Roof Downblast Exhaust
 Size-140: GB • G
 Previously Size- GB-141 • G-143

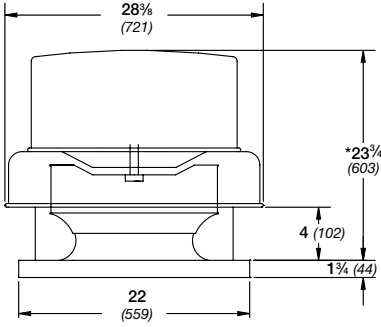

Damper Size = 16 x 16 (406 x 406)
 Roof Opening = 18½ x 18½ (470 x 470)
 Shroud Thickness = 0.051 (1.3)
 Motor Cover Thickness = 0.040 (1.0)
 Curb Cap Thickness = 0.064 (1.6)

*Approximate Unit Weight G/GB = 77/86 lbs. (35/39 kg)

All dimensions in inches (millimeters). *May be greater depending on motor. ^Weight shown is largest cataloged Open Drip-Proof motor.

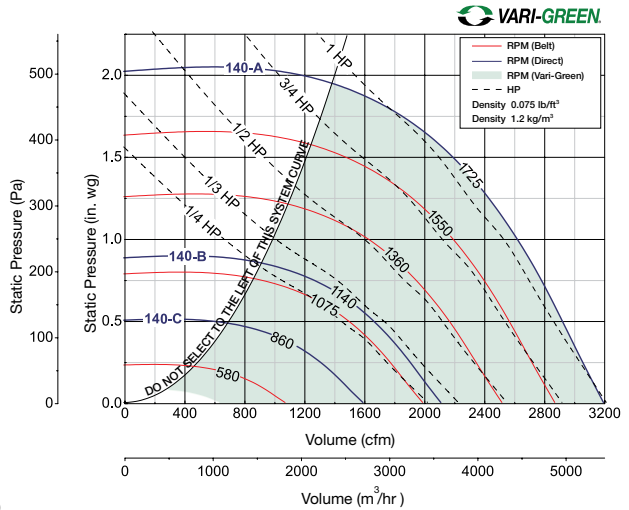

Direct Drive RPM			
C-860 RPM	B-1140 RPM	A-1725 RPM	VG-1725 RPM

Belt	Motor HP		Fan RPM	Static Pressure in Inches wg												
	Belt	Direct		0	0.125	0.25	0.375	0.5	0.75	1	1.25	1.5	1.75			
140																
1/4	VG-1/4	VARI-GREEN	580	CFM	1076	855										
				BHP	0.04	0.04										
				Sones	4.7	4.7										
			720	CFM	1336	1169	938									
				BHP	0.07	0.08	0.08									
				Sones	5.8	5.9	5.2									
	C-1/8	860	CFM	1595	1457	1304	1085									
			BHP	0.12	0.13	0.13	0.13									
			Sones	7.1	7.0	6.6	6.1									
		950	CFM	1762	1636	1506	1344	1085								
			BHP	0.16	0.17	0.18	0.18	0.17								
			Sones	8.1	8.0	7.6	7.1	6.5								
VG-1/2	1075	CFM	1994	1882	1771	1647	1490									
		BHP	0.24	0.25	0.26	0.26	0.26									
		Sones	10.0	9.9	9.4	8.9	8.4									
	B-1/3	1140	CFM	2115	2008	1905	1792	1660	1233							
			BHP	0.28	0.30	0.31	0.31	0.31	0.29							
			Sones	11.0	10.9	10.4	9.9	9.4	8.2							
1/2	VG-3/4	1265	CFM	2347	2250	2158	2062	1955	1677	1048						
			BHP	0.39	0.40	0.41	0.42	0.42	0.42	0.35						
			Sones	12.9	12.7	12.3	11.9	11.4	10.4	8.8						
		1360	CFM	2523	2433	2347	2259	2166	1943	1602						
			BHP	0.48	0.50	0.51	0.52	0.52	0.53	0.51						
			Sones	14.6	14.3	13.9	13.5	13.1	12.2	11.0						
3/4	VG-1	1450	CFM	2690	2606	2524	2443	2358	2165	1905	1501					
			BHP	0.58	0.60	0.61	0.63	0.63	0.64	0.63	0.59					
			Sones	16.2	15.9	15.6	15.2	14.7	13.8	12.9	11.7					
		1550	CFM	2875	2797	2719	2644	2566	2396	2191	1910	1297				
			BHP	0.71	0.73	0.74	0.76	0.77	0.78	0.79	0.76	0.65				
			Sones	17.7	18.0	17.4	17.2	16.8	15.0	14.8	14.8	14.9				
1	A-1	1725	CFM	3200	3129	3059	2991	2923	2782	2619	2427	2184	1815			
			BHP	0.98	1.00	1.02	1.03	1.05	1.07	1.07	1.09	1.06	1.00			
			Sones	20.0	21.0	20.0	19.9	19.6	18.5	17.2	17.0	16.8	16.7			

MAXIMUM BHP AT A GIVEN RPM = (RPM/1676)³
 MAXIMUM RPM = 1725
 TIP SPEED (ft/min) = RPM x 3.829
 MAXIMUM MOTOR FRAME SIZE = 145T

Performance certified is for installation type A: Free inlet, Free outlet. Power rating (BHP) does not include transmission losses. Performance ratings include the effects of a birdscreen. The sound ratings shown are loudness values in hemispherical soundes at 5 ft. (1.5 m) in a hemispherical free field calculated per AMCA Standard 301. Values shown are for installation type A: free inlet hemispherical sone levels.

MODEL RBU

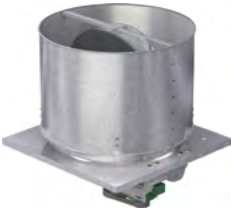

- Belt Drive Propeller Upblast Fans
- Belt drive propeller upblast fan
- Heavy gauge galvanized construction
- Adjustable motor plate
- Static & oil free belts
- Aluminum butterfly dampers for weather protection and to prevent backdrafts
- NEMA-3R disconnect
- ODP motor
- 480/3 voltage 3 Phase, galvanized roof curb

	Size	HP	Curb Cap
RBU-2L48	36,500 CFM @ 0.1 SP	5HP	58 × 58
RBU-3L60-75	50,000 CFM @ .125"	7.5HP	72.5" × 72.5"

Dimensional Data Level 1, 2 and 3 Models RBU and RBUMO



Model RBU

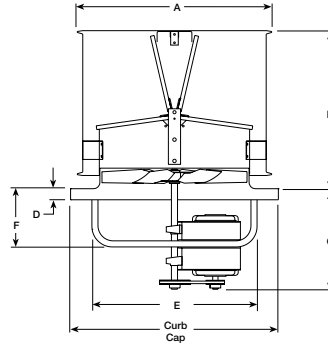

Model Size	A	B	C*		D	E	F	Curb Cap (Inside)	Maximum Recommended Roof Opening
			Level						
			1, 2	3					
24	31-1/8	26	15-1/2	16-3/4	1-3/4	27-3/8	9-7/16	34	30-1/2
30	37-3/8	30	15-1/2	16-3/4	1-3/4	34-3/4	9-7/8	40	36-1/2
36	43-1/2	33	16-3/4	16-3/4	1-3/4	40-7/8	9-7/8	46	42-1/2
42	49-5/6	38	19-3/8	23-7/8	1-3/4	46-3/4	11-3/4	52	48-1/2
48	56	40	19-3/8	23-7/8	1-3/4	52-3/4	11-3/4	58	54-1/2
54	62-5/8	45	19-1/4	26-7/8	1-3/4	61-1/4	11-1/2	66-1/2	63
60	68-3/4	48	21-1/4	27	1-3/4	66-1/4	15	72-1/2	69

All dimensions are in inches. *Dimension may vary depending on motor.



Model RBUMO

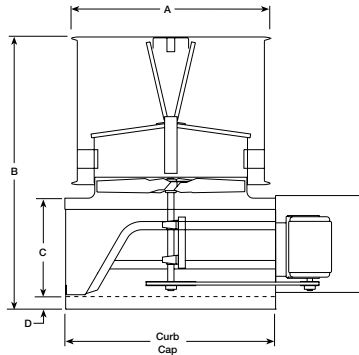

Model Size	A	B*	C*	D	Curb Cap (Inside)	Maximum Recommended Roof Opening
24	31-1/8	45-5/6	17-1/2	2-1/4	33-1/2	30
30	37-3/8	51-3/4	19-1/2	2-1/4	39-1/2	36
36	43-1/2	55	19-1/2	2-1/4	45-1/2	42
42	49-5/6	59-5/8	19-5/8	2-1/4	51-1/2	48
48	56	63-5/6	21-3/4	2-1/4	57-1/2	54
54	62-5/8	70-5/8	22-3/4	2-1/4	66	62-1/2
60	68-3/4	75	23	2-1/4	72	68-1/2

All dimensions shown in inches. *Sizes greater than 36 with high temperature option will be 5 inches larger. *Dimension may vary depending on motor.

Dimensional Data Model RDU

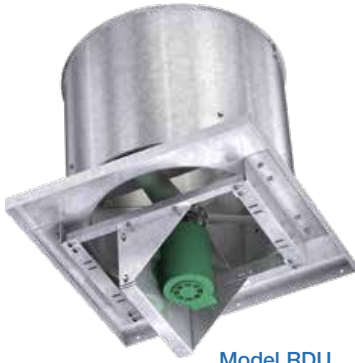

Model RDU

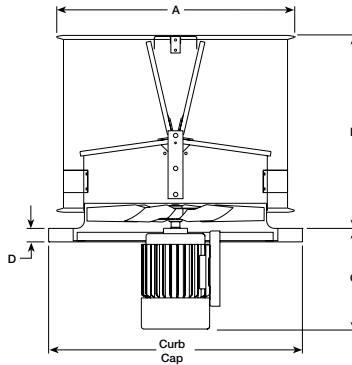

Model RDU - Direct Drive						Maximum Recommended Roof Opening
Model Size	A	B	C*	D	Curb Cap (Inside)	
24	31-1/8	26	13-1/2	1-3/4	34	30-1/2
30	37-3/8	30	13-1/8	1-3/4	40	36-1/2
36	43-1/2	33	12-15/16	1-3/4	46	42-1/2
42	49-5/6	38	18-1/2	1-3/4	52	48-1/2
48	56	40	18-1/2	1-3/4	58	54-1/2

All dimensions shown in inches. *Dimension may vary depending on motor.

Weights

Level 1, 2 and 3 Models RBU and RBUMO

Approximate Weights*							
Model Size	Level 1		Level 2		Level 3		
	RBU	RBUMO	RBU	RBUMO	RBU	RBUMO	RDU
24	170	248	174	254	178	262	200
30	232	335	242	346	273	368	218
36	267	385	292	410	327	440	288
42	-	-	411	535	418	542	351
48	-	-	555	703	602	750	484
54	-	-	705	848	717	915	-
60	-	-	-	-	817	1063	-

*Approximate weight does not include accessories. *Weight shown in pounds.

MODEL RDC



Round Transitions for SP Fans
6" or 8"

SP REPLACEMENT GRILLE



Replacement Grille for SP Fans
B50-B200, A50-A390

MODEL CRD-300, 310, 320



- Radiation Damper for SP Fans
- 300 / used with SP-LP0511-1
- 310 / used with SP-A110, A125
- 320 / used with SP-A200 through 390 and all SP-B models

SPEED CONTROLLER



- Solid State Speed Controller
- 115v fan speed controller
- Adjusts fan to 60% of design airflow

MODEL VI KIT



Neoprene Hangers for SP/CSP Fans

HVLS KEYPAD



- Keypad style controller for single fan control
- Controls speed and direction
- Provides full status monitoring capability and fault-logging

HVLS TOUCHPAD



- Touchscreen style controller for either single fan or 10 fans
- Controls speed and direction
- Offers password protection and advanced diagnostics

SPEED DIAL VG



- Plug in dial for EC motor (VG fans) for speed control

MODEL ESD-435



- Drainable Blade Louvers
- Extruded aluminum louver
- 4" deep,
- Flange frame
- 0.081" thick frame and blades
- 37.5° blades on 3-1/4" centers
- Galvanized birdscreen
- 1/4" undersized
- Mill finish

Sizes
12" × 12"
16" × 16"
18" × 12"
18" × 18"
24" × 24"

MODEL BV



- Brick Vents
- Extruded aluminum brick vent
- 4" deep
- Box frame
- 0.125" thick frame & blades
- 45° blades
- Galvanized insect screen
- Clear anodized finish

Sizes
8" × 8"
12" × 8"
16" × 8"

WALL CAPS



MODEL WC



- Round Wall Caps
- Aluminum construction
- Built in birdscreen on 6" thru 12"
- Built in backdraft damper
- Mill finish

Sizes				
4"	6"	8"	10"	12"

FANS

MODEL WC

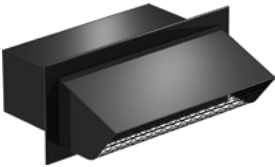

- Rectangular Wall Caps
- Steel construction
- Built in birdscreen
- Built in backdraft damper
- Black enamel finish

Sizes	
8" x 8"	10" x 3"

MODEL RJ



- Roof Jacks
- Steel construction
- Built in birdscreen
- Built in backdraft damper
- Integral flashing flange
- Black enamel finish

Sizes		
4"	6" × 9"	10" × 10"

MODEL GRS



- Roof Gravity Vents
- Spun Aluminum, birdscreen

Size	Curb Cap	Damper Size
8"	19" × 19"	8" × 8"
10"	19" × 19"	10" × 10"
12"	22" × 22"	12" × 12"
16"	26" × 26"	16" × 16"
20"	30" × 30"	18" × 18"
24"	34" × 34"	24" × 24"

**OPTIONAL BDD AVAILABLE*

MODEL RCC-7



- Flange Roof Gravity Cap
- Aluminum construction
- Integral birdscreen
- Curb cap for curb mounting
- Mill finish

Curb Cap Size
15" × 15"

VENT CAP

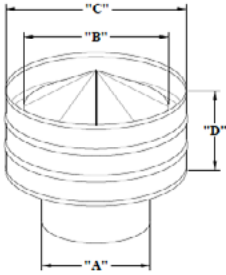

- Galvanized steel construction
- Per ASTM-A653 CS Type B
- Order by "A" dimension
- With ½" hardware cloth screen

Sizes
6", 8", 10", 12"

STORM COLLAR

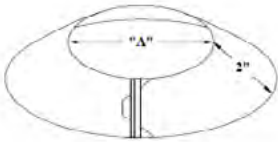

- Galvanized steel construction
- Per ASTM-A653 CS Type B
- Order by A Dimension

Sizes
6", 8", 10", 12"

ROOF FLASHING

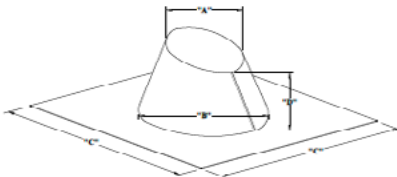

- Galvanized steel construction
- Per ASTM-A653 CS Type B
- Order by "A" dimension
- 4/12 pitch standard

Sizes
6", 8", 10", 12"

PIPE BOX

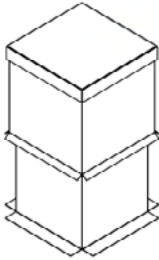

- 12x12 Pipe Box w/ Removeable Top
- Galvanized steel (18 gauge)
- Fully welded
- 3#, 1.5" yellow board insulation
- Removable insulated cover
- Pipe openings to be field cut & sealed

Neck Size	Height
12" x 12"	14"
18" x 18"	14"

MODEL RPS

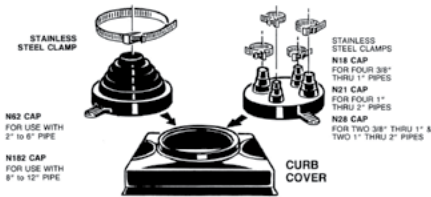

- Pipe Portals
- Molded ABS plastic cover
- Molded EPDM rubber caps
- Stainless steel clamps
- N28 (2) 3/8"-1" & (2) 1"-2" pipes
- N62 (1) 2"-6" pipe

Curb Cap Size
13" x 13"

DRYER BOOSTER FANS & ACCESSORIES



MODEL DBF-4XLT



- Dryer Booster Fan
- Dryer booster fan
- UL 705 & CSA C22.2
- Pressure-sensing switch automatically turns on fan
- LED indicator display panel & temperature limit switch
- HVI certified
- 115/1 voltage

MODEL DBF-110



- Dryer Booster Fan
- Dryer booster fan
- UL 507
- Pressure-sensing switch automatically turns on fan
- HVI certified
- 115/1 voltage

MODEL DRYERBOX 425



- Dryerbox
- Aluminized steel (22 gauge)
- 4.25" deep
- For 2×6 walls (2×4 with an added furring strip)
- Upward venting

DRYER BOOSTER FANS & ACCESSORIES



MODEL DBLT



- Dryer Lint Trap
- Galvanized steel
- Fits 4" ductwork
- Reduces lint accumulation in duct

MODEL NRC



- Roof Curbs
- Galvanized construction (18 gauge)
- 14" high flat
- Fully welded one-piece construction
- Pressure treated 2×2 wood nailer
- 3#, 1-1/2" thick fiberglass insulation
- Primer paint

Size	Actual OD Size	Size	Actual OD Size
15" × 15"	13.5" × 13.5"	30" × 30"	28.5" × 28.5"
17" × 17"	15.5" × 15.5"	34" × 34"	32.5" × 32.5"
19" × 19"	17.5" × 17.5"	40" × 40"	38.5" × 38.5"
22" × 22"	20.5" × 20.5"	46" × 46"	44.5" × 44.5"
24" × 24"	22.5" × 22.5"	58" × 58"	56.5" × 56.5"
26" × 26"	24.5" × 24.5"	72" × 72"	70.5" × 70.5"

MODEL ES

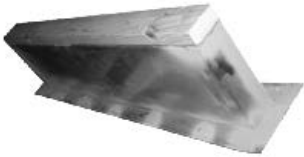

- Equipment Rails
- Galvanized construction (18 gauge)
- 14" high flat
- Fully welded one-piece construction
- Pressure treated 2×4 wood nailer (3-1/2" width)
- Primer paint

Lengths
24"
48"
36"



HANDMADE WITH CARE

Corporate Overview

We are dedicated to empowering businesses to achieve their full potential. With a team of seasoned professionals and a wealth of industry experience, we offer tailored consulting services to help organizations overcome challenges and seize opportunities.

Profile:

-  A private Canadian company founded in 1976.
-  Designs, manufactures, and distributes HVAC products.
-  Over 300 dedicated employees.
-  State-of-the-art facility spanning over 100,000 sq. ft.
-  Ongoing commitment to Research and Development (R&D).
-  A highly skilled distribution network spanning the globe.
-  Broad and diverse customer base attesting to its global impact.

Entire manufacturing chain under one roof

At our facility, the entire spectrum of our manufacturing chain, from product development to support services, operates cohesively under one roof. Our unified approach is dedicated to meeting the dynamic demands of our industry and, more importantly, our valued customers. This model of vertical integration not only expedites our lead times but also enhances product development, facilitates customized OEM solutions, and ensures stringent quality control measures, significantly contributing to the overall excellence of our products and services.

Recognized leader worldwide

With over 70% of our sales directed towards international markets, our product marketing is strategically tailored to cater to a diverse customer base and distribution network spanning across 60 countries.

E30552T2DWB



Redd-i

- Electric wall heater
- Heavy duty 18 gauge steel construction
- Powder coated paint finish
- Automatic over-heat limit protection
- 100 cfm / 600 RPM
- Factory installed tamper proof thermostat
- Factory installed fan delay
- Factory installed disconnect
- Rough in dimensions 9-1/4" wide × 12-1/8" high × 3-5/8" deep
- Temp range 40-100° F

Model	Voltage	KW
E30552T2DWB	120/1	0.75/1.5
305EX32	Surface Mount Frame	

MODEL AFA



Redd-i

- Electric wall heater
- Heavy duty 18 gauge steel construction
- Powder coated paint finish
- Automatic over-heat limit protection
- 175 cfm / 600 rpm
- Factory installed tamper proof thermostat
- Factory installed fan delay
- Factory installed disconnect
- Rough in dimensions 14-1/8" wide × 19-1/2" high × 4" deep
- Temp range 0-110°F

Model	Voltage	KW
AFA115D	120/1	1.5
AFA220D	208/1	1.5
AFA230D	208/1	3
AFA840D	208/1	4
AFA720D	277/1	2
AFA730D	277/1	3
AFA740D	277/1	4
AFAEX33	Surface Mount Frame	

MODEL RCH

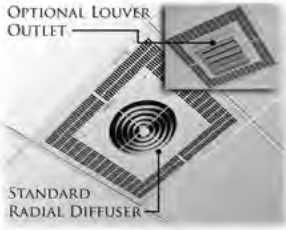

Redd-i

- Electric ceiling heater
- 20 gauge steel
- 80/20 heater elements
- Lay-in frame
- 600 cfm
- Factory installed thermostat
- Factory installed disconnect
- Temp range 40-110 °F

Model	Voltage	KW
71RCH2A1	277/1	2
71RCH3A1	277/1	3
71RCH4A1	277/1	4
81RCH2A1	208/1	2
81RCH3A1	208/1	3
81RCH4A1	208/1	4

MODEL CWH



- Electric wall heater
- White commercial-grade steel grille
- Powder coated finish
- Automatic over-heat limit protection
- 65 cfm
- Single pole thermostat
- Double pole on/off switch
- Temp range 40-85°F

Model	Voltage	KW
CWH1151DS	120/1	7.5/1.5

MODEL AWH



- Electric wall heater
- Heavy duty 18 gauge steel construction
- Powder coated paint finish
- Automatic over-heat limit protection
- 100 cfm
- Factory installed tamper proof thermostat
- Factory installed fan delay
- Factory installed disconnect
- Temp range 40-90°F

Model	Voltage	KW
AWH4404	208/1	1.5/3
AWH4407	277/1	2/4
AWH4408	208/1	2/4
AWHSM		Surface Mount Frame

MODEL CDF



- Electric ceiling heater
- 20 gauge steel
- 80/20 heater elements
- Lay-in or Surface mount frame available
- 300 cfm
- Temp range 45-90°F

Model	Voltage	KW
CDF547	277/1	2/3/4
CDF548	208/1 or 3	2/3/4
CDF-RE*	Recessed Lay-in Frame	
CDF-SE*	Surface Mount Frame	
CDF-T*	Thermostat 45 – 95°F	
CDF-DS*	Disconnect Switch	
CDF-TR4*	208/240 Primary Transformer / 24V	
CDF-TR7*	277 Primary Transformer / 24V	

**ALL ACCESSORIES FIELD MOUNTED*

MODEL CUH



- Electric unit heater
- Heavy duty die-formed steel housing
- Two toned with stainless steel louvers
- Horizontal or vertical mounting
- Fan delay eliminates cold drafts

Model	Voltage	KW
MUH0371	277/1	3
MUH0541	480/3	5
MUH0581	208/1 or 3	5
MUH072	240/1 or 3	7.5
MUH074	480/3	7.5
MUH104	480/3	10
B10*	Mounting Bracket	
MT1	Thermostat 40-85°F	
MPDS25	Disconnect Switch (25A)	

**ALL ACCESSORIES FIELD MOUNTED*

MODEL GUH



- 20 gauge aluminized steel tubular heat exchanger
- ETL Certified
- 83% thermal efficiency
- Power vented
- Direct spark ignition
- Redundant single stage gas valve
- Rear burner access
- Individually adjustable and removable horizontal louvers
- 10 year heat exchanger, flue collector and burner warranty

Inputs		
200,000 Btu/h	300,000 Btu/h	400,000 Btu/h

MODEL ETD9STS



- Heat/Cool Thermostat
- Line voltage thermostat (120v - 277v)
- Single pole
- Heat/cool
- 50-90° F range
- White



THE BEST RELY ON FRANKLIN CONTROL SYSTEMS

Franklin Control Systems (FCS) is well known throughout not just the HVAC industry, but also the agriculture and manufacturing community for their innovative and reliable motor controls. Located in Portland, Oregon, they sell through an established network of top-end distributors in the United States and Canada that offer superior products and customer service. FCS offers a full line of motor controls from Variable Frequency Drives to components and is currently partnered with several other industry leading OEMs, including Greenheck Fan Company.



BAS Starter Q-Link VFD

Innovative products

Products like the Q-Link VFD with intuitive smartphone operation are on the leading edge of controls technology. The drive was designed from the ground up for HVAC applications and users in that industry, with streamlined start-up, reporting, and support.

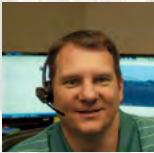

Live tech support

When you call FCS, you'll always be directed to a live voice during business hours. After hours, an automated system will connect you with one of our skilled Application Engineers.



Industry-leading warranty

Franklin Control Systems stands behind their products with an industry-leading 5-year warranty.

CONTROL SYSTEMS

MODEL BAS



Building Automation Starter

3Ø, 200~600V, ½-30HP

Equipped with advanced I/O including Fireman's Override and damper control, the BAS was designed from the ground up for easy integration with automation systems. With a 200 to 600V input and 1-40A adjustable overload, the BAS is the right starter for almost any job.

MODEL BAS-1P



1Ø Building Automation Starter

1Ø, 110V, 1/10 - 1HP | 1Ø, 240V, 1/10 - 1HP

The BAS-1P protects single phase motors with an adjustable 1-16A class 10 electronic overload. It includes features like run status verification, a concealed Hand/Auto switch, lockable on/off switch, and system override mode (smoke purge). All of this in a compact design that installs on a single junction box.

SIZING INFORMATION TABLE

[] is representative of the enclosure type, please insert either 1 (UL Type 1 enclosure), 3R (UL Type 3R outdoor enclosure), 4XS (UL Type 4X Stainless Steel), or 12 (UL Type 12 enclosure) when identifying your Part Number(s).

Building Automation Starter - 1 & 3-Phase, 50/60 Hz, 200~600 VAC
UL Type 1/3R/12 Enclosed - Combination Starter, Electronic Overload
Includes MCP Disconnect

Part Number	UL HP Ratings					SCIC KAIC @			Contactor NEMA Size	Contactor Type	Disconnect Part Number
	1Ø		3Ø			240V	460V	600V			
	230V	208V	230V	460V	600V						
BAS[-]9/P-G16-40	1/10	-	-	3/4	3/4	100	65	25	00	MRC-9B	CMS-32HI-16
BAS[-]9/P-G2.5-40	1/6	1/2	1/2	1	1.5	100	65	25			CMS-32HI-2.5
BAS[-]9/P-G4-40	1/3	3/4	3/4	2	3	100	65	25			CMS-32HI-4
BAS[-]9/P-G6-40	1/2	1	1.5	3	3	100	65	25			CMS-32HI-6
BAS[-]9/P-G8-40	1	2	2	5	5	100	65	25			CMS-32HI-8
BAS[-]18/P-G10-40	1.5	2	3	5	7.5	100	65	25	0	MRC-18B	CMS-32HI-10
BAS[-]18/P-G13-40	2	3	3	7.5	10	100	65	25			CMS-32HI-13
BAS[-]18/P-G17-40	3	3	5	10	15	100	30	10			CMS-32HI-17
BAS[-]32/P-G22-40	3	5T	7.5	15	20	100	30	10	1	MRC-32A	CMS-32HI-22
BAS[-]32/P-G26-40	3	7.5	7.5	15	20	100	30	10			CMS-32HI-26
BAS[-]32/P-G32-40	5	7.5	10	20	25	100	30	10			CMS-32HI-32
BAS[-]40/P-G40-40	7.5	10	10	30	30	100	30	10	1+	MRC-40A	CMS-32HI-40

Building Automation Starter - 1 & 3-Phase, 50/60 Hz, 200~600 VAC
UL Type 1/3R/12 Enclosed - Standard Starter, Electronic Overload
Disconnect Not Included

Part Number	UL HP Ratings					SCIC KAIC @			Contactor NEMA Size
	1Ø		3Ø			240V	460V	600V	
	230V	208V	230V	460V	600V				
BAS[-]9/P-40	1	2	2	5	7.5	5	5	5	00
BAS[-]18/P-40	3	5	5	10	15	5	5	5	0
BAS[-]32/P-40	5	7.5	10	20	25	5	5	5	1
BAS[-]40/P-40	7.5	10	10	30	30	5	5	5	2

NEMA 1/3R Factory Installable Options

Part Number	Description
BAS-1PH	Single Phase Wiring for BAS Starters

Consult factory for type 4 & 4X enclosed EMS starters



BAS Specifications

BAS Specification

Starter Type

BAS - Building Automation Starter

200-600VAC, 3-Phase, 50/60Hz input, Across the line, full-voltage non-reversing

UL Type 1, 3R, or 12 Enclosed

User Interface

Hand/Off/Auto Keypad with LED mode indication

Standard Control Operations

Inputs	Voltage Auto-Run	Accepts 12-250VAC/DC. Applying voltage will send a run command to the starter when in Auto mode.	
	Dry Contact Auto-Run	Normally Open dry contact. When closed, the starter will be commanded to run when in Auto mode.	
	Fireman's Override	Accepts 12-250VAC/DC. Applying voltage will cause the starter to run in all modes and all LEDs will flash.	
	Shutdown	Normally Closed dry contact. When closed, the starter will disengage the contactor and will not accept a run command (except Fireman's Override). Hand/Off/Auto LEDs will flash.	
	Permissive Auto	Normally Closed dry contact. When closed, the starter will not accept run commands in Auto mode (except Fireman's Override)	
	Damper Limit Switch	Normally Open dry contact. When used with the damper motor output, the contactor coil is in series with customer provided damper contacts which disable the motor starter until the damper is in position.	
Outputs	Status Relay	Normally Open relay contacts. Status Relay will close when the motor draws 60% of the FLA dial setting.	Contact Ratings: 110VDC, 0.3A Resistive 125VDC, 0.5A GP 30VDC, 2.0A Resistive 120VAC 50/60Hz, 0.5A Resistive 125VAC 50/60Hz, 1.0A GP 240VAC 50/60Hz, 0.25A Resistive
	Fault Relay	Fault Relay will close in the event of a fault trip.	
	Damper/Actuator	24VDC, 1A max.	
Operational	Overload Type	Electronic I ² t trip curve	
	Fault Reset	Manual (default) or Automatic	
	Power Fail Modes	Return to last mode the starter was placed in (Hand/Off/Auto) with no delay (default) Return to last mode the starter was placed in (Hand/Off/Auto) with a 10 second delay Return to Off mode (LED of last mode the starter was placed in will be flash)	

Environmental

Ambient Operating Temp -5° to 140° F (-20° to 60° C)

Ambient Storage Temp -5° to 185° F (-20° to 85° C)

Relative Humidity 5% to 95% non-condensing

Motor Protection	Adjustment / Description	Default Setting
Overload Current Setting Range	1-40A	Per FLA
Overload Trip Class	Adjustable: Class 10 or 20, Trip current = 115% of FLA setting	Class 10
Cycle Fault	Trip if cycle rate exceeds 20 starts/minute	Always On
Stall	Trips within 0.5 seconds (disabled during startup)	Always On
Protection	Adjustment / Description	Default Setting
Current Phase Unbalance	Trips within 3 sec @ 25% current unbalance. *Trip threshold changes to 80% unbalance when switched to Off	On
Locked Rotor	Trips within 0.5 seconds	
Out of Calibration	On/Off Trips after 10 seconds if the FLA dial setting is incorrect (set above calculated FLA range), ie. Start current is outside of an acceptable range (fla setting * 5 < Inrush < fla setting * 14).	
Max Time to Start	Regardless of FLA or I ² t curve, always trip at start if starting current is outside of an acceptable range (inrush / 5) and still decreasing after 10 seconds.	

WIRING DIAGRAMS

BAS CONTROL WIRING

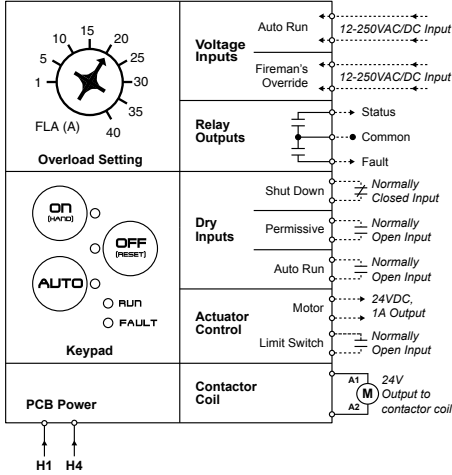

BAS POWER WIRING

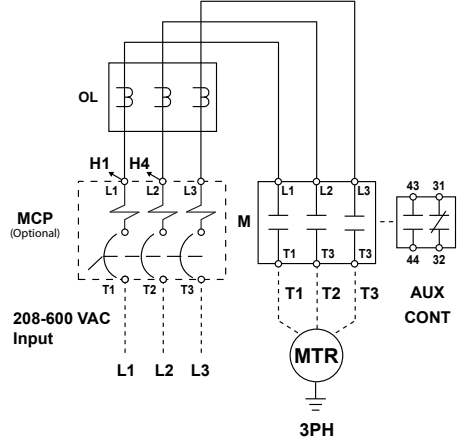

BAS 1-PHASE CONTROL WIRING

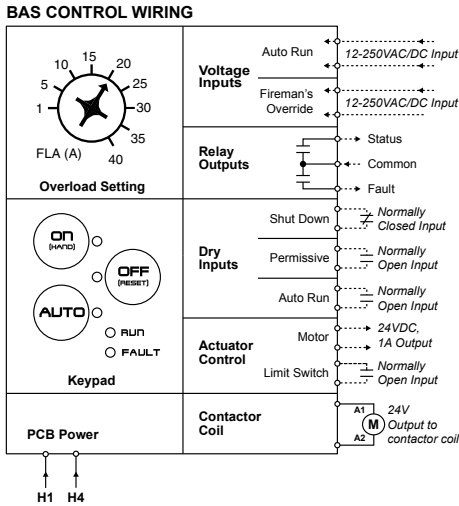

BAS 1-PHASE POWER WIRING

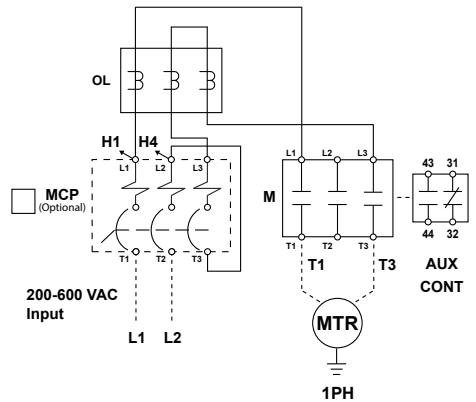

SCHM-BAS/1PH-V3

COMPONENT SPECIFICATIONS

The following section details the various components' sizing and ratings. To locate your component part numbers for the BAS reference the sizing information table above.

THREE POLE CONTACTORS



MANUAL MOTOR STARTERS



3-POLE CONTACTOR SPECIFICATIONS

Type			MRC-9B	MRC-18B	MRC-32A	MRC-40LA	
Frame Size			22AF		40AF		
Terminal Type			Screw		Screw		
Number of poles			3 pole		3 pole		
Rated operation voltage, Ue			690V		690V		
Rated insulation voltage, Ui			690V		1000V		
Rated frequency			50/60Hz		50/60Hz		
Rated impulse withstand voltage, Uimp			6kV		8kV		
Max. operating rate in operating cycles per hour (AC3)			1800 operations per hour		1800 operations per hour		
Durability	Mechanical		15 mil. operations		12 mil. operations		
	Electrical		2.5 mil. operations		2 mil. operations		
Current and power	AC-1, Thermal current	A	25	40	50	60	
		kW	2.5	4.5	7.5	11	
	200/240V	A	11	18	32	40	
		kW	4	7.5	15	18.5	
	iAC-3	380/440V	A	9	18a	32	40
			kW	4	7.5	18.5	22
500/550V	A	7	13	28	32		
	kW	4	7.5	18.5	22		
UL rating (50/60Hz)	Continuous current	A	25	40	50	60	
		HP	0.5	1	2	3	
	Single Phase	110~120V	HP	1.5	3	5	7.5
		220~240V	HP	2	5	7.5	15
	Three Phase	200~208V	HP	3	7.5	10	15
		220~240V	HP	5	10	20	30
440~4 80V	HP	7.5	15	25	30		
550~600V	HP	00	0	1	-		
Size and weight	MRC	Weight	0.73 lbs		0.88 lbs		
			1.77 x 2.89 x 3.39 in		1.77 x 3.27 x 3.54 in		
	MRD	Weight	112 lbs		1.32 lbs		
			1.77 x 2.89 x 4.63 in		1.77 x 3.27 x 4.61 in		
Auxiliary (standard)			1NO & 1NC		1NO & 1NC		
Auxiliary	Side mount		MA-1		MA-1		
	Front mount		CA-2, CA-4		CA-2, CA-4		



STARTER ENCLOSURE DIMENSIONS

UL Type 1 Dimensions

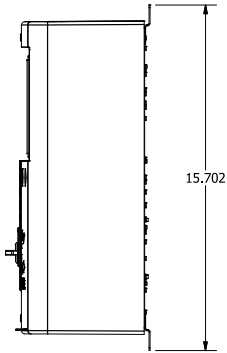
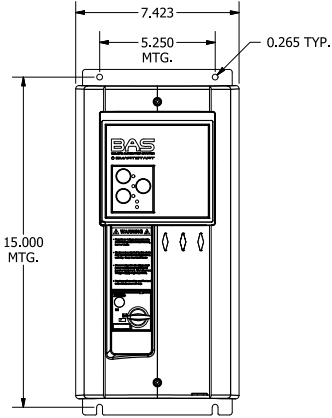

All dimensions are in inches

UL Type 3R Dimensions

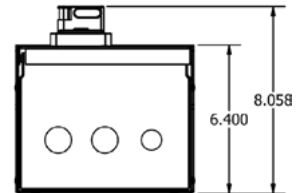
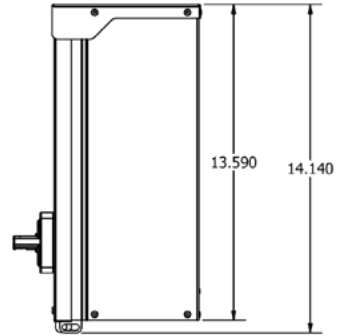
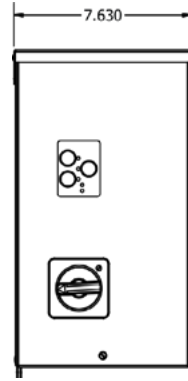

All dimensions are in inches

World Leader in HVAC Noise Control

VIBRO-ACOUSTICS®
A Swegon Group company

PRODUCTS

Our wide range of noise control products and services include:

- > Rectangular / Circular / Elbow silencers for HVAC applications
- > Cross Talk silencers
- > VAV Box Silencers
- > Air Cooled Chiller Noise Control
- > Cooling tower Noise Control
- > Generator Noise Control
- > RTU Integrated Noise Control Curbs
- > Garage and tunnel fan exhaust



OVER 55 YEARS IN HVAC NOISE CONTROL.

VIBRO-ACOUSTICS IS A TORONTO, CANADA BASED COMPANY with four manufacturing facilities across North America. Our 15 application engineers can design noise control solutions for anything that creates airborne or structure-borne noise inside or outside a building. Vibro-Acoustics also has a NAVLAP accredited ASTM-E477 testing lab for in-house silencer testing.



Whether its maintaining a proper noise control level inside the building or meeting specific dBA requirements outside at the property line we have you covered.

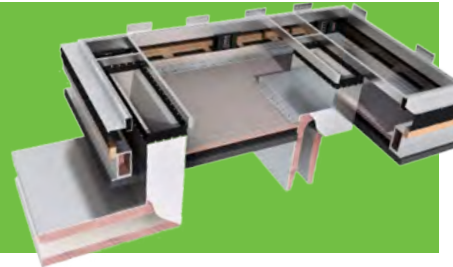

MODEL MI-HD



- LDS Rubber Hangers
- Neoprene

Model	Max Load	Deflection
MODEL HD-A-BLACK	45 LBS	0.35"
MODEL HD-A-GREEN	75 LBS	0.35"
MODEL HD-A-RED	125 LBS	0.35"
MODEL HD-B-WHITE	380 LBS	0.40"

MODEL MI-HS



- Spring Hangers

Model	Max Load	Deflection
HS-X-54-WHITE	54 LBS	1.20"
HS-X-113-YELLOW	113 LBS	1.0"
HS-X-175-SILVER	175 LBS	1.0"
HS-A-310-YELLOW	310 LBS	1.00"

MODEL MI-30N



- Spring & Neoprene Hangers

Model	Max Load	Deflection
30N-X-76-BLACK	76 LBS	1.22"
30N-X-175-SILVER	175 LBS	1.20"
30N-B-278-PURPLE	278 LBS	1.44"

MODEL MI-SLFH



- Floor Mounted Spring Isolator
- with baseplate and leveling bolt

Model	Max Load	Deflection
SLFH-A-75-ORANGE	75 LBS	1.5"
SLFH-A-125-BROWN	125 LBS	1.33"

MODEL MI-C RESTRAINED



Model	Max Load	Deflection
C-A-125-BROWN	125 LBS	1.33"
C-A-200-BLACK	200 LBS	1.15"

MODEL MI-SW



- Vibration Isolation Pads
- ¾" Thick, 0.1" Deflection

Model	Size	Rated Load
SW-R2X2	2" × 2" NEOPRENE PAD	120 LBS
SW-R3X3	3" × 3" NEOPRENE PAD	270 LBS
SW-R18X18	18" × 18" NEOPRENE PAD	9,720 LBS



prihoda®

Tailor-made Air Ducting & Diffusers

NORTH AMERICA

Custom Textile Air Distribution

Prihoda custom fabric air distribution systems provide cost effective-solutions for simple installations like pools and gymnasiums...



...or engineered air distribution solutions like Georgia Tech's O'Keefe building which required comfortable heating and cooling in open office areas...

... or systems to meet extremely low sound level requirements like at Tyler Perry Studios.



Systems can even be printed with any color, any image, any pattern to work perfectly with any space aesthetic.

BASIC FAN LAWS

$$\begin{aligned}
 a &= \text{NEW} & b &= \text{OLD} \\
 CFM_a &= CFM_b \times \frac{RPM_a}{RPM_b} & RPM_a &= RPM_b \times \frac{CFM_a}{CFM_b} \\
 SP_a &= SP_b \times \left(\frac{RPM_a}{RPM_b}\right)^2 & HP_a &= HP_b \times \left(\frac{RPM_a}{RPM_b}\right)^3
 \end{aligned}$$

$$\text{Friction Loss per 100 ft.} = \frac{\text{System design pressure} \times 100}{\text{Total equiv. length of duct}}$$

BASIC AIR CONDITIONING FORMULAS

COOLING	HEATING and/or HUMIDIFYING
$H_S = CFM_T \times 1.08 \times (T_1 - T_2)$	$H_S = CFM_T \times 1.08 \times (T_2 - T_1)$
$H_L = CFM_T \times .68 \times (W_1 - W_2)$	$H_L = CFM_T \times .68 \times (W_2 - W_1)$
$H_T = CFM_T \times 4.5 \times (h_1 - h_2)$	$H_T = CFM_T \times 4.5 \times (h_2 - h_1)$
$T_1 = t_1 + \frac{CFM_O \times (t_2 - t_1)}{CFM_T}$ ① If duct heat gain is a factor, add to T_1 : $\frac{\text{Duct Heat Gain (Btuh)}}{CFM_T \times 1.08}$	$T_1 = t_1 - \frac{CFM_O \times (t_2 - t_1)}{CFM_T}$ ② If duct heat loss is a factor, subtract from T_1 : $\frac{\text{Duct Heat Loss (Btuh)}}{CFM_T \times 1.08}$
$T_2 = T_1 - \frac{H_S}{CFM_T \times 1.08}$	$T_2 = T_1 + \frac{H_S}{CFM_T \times 1.08}$
$CFM_T = \frac{H_S (\text{total})}{1.08 \times (T_1 - T_2)}$	$CFM_T = \frac{H_S}{1.08 \times (T_2 - T_1)}$
OR $CFM_T = \frac{H_S (\text{internal})}{1.08 \times (t_1 - t_2)}$ ③ Sensible load of outside air not included.	
① $h_2 = h_1 - \frac{H_T}{CFM_T \times 4.5}$	② $h_2 = h_1 + \frac{H_T}{CFM_T \times 4.5}$

Leaving Air W.B. Temperature: Refer to Enthalpy Table and read W.B. temperature corresponding to enthalpy of leaving air (h_2).

For Cooling see ① For Heating see ②

FOLLOWING FORMULA APPLY FOR EITHER COOLING OR HEATING and/or HUMIDIFYING

$$\begin{aligned}
 CFM_T &= \frac{N_T V}{60 \text{ min/hr}} & N_T &= \frac{CFM_T (60 \text{ min/hr})}{V} \\
 CFM_O &= \frac{N_O V}{60 \text{ min/hr}} & N_O &= \frac{CFM_O (60 \text{ min/hr})}{V}
 \end{aligned}$$

LEGEND FOR FORMULAS

CFM_T = Total airflow cu. ft./min.
 CFM_O = Outdoor air cu. ft./min.
 N_T = Total air changes/hr.
 N_O = Outdoor air changes/hr.
 V = Volume of space cubic feet
 H_T = Total heat Btuh
 H_S = Sensible heat Btuh
 H_L = Latent heat Btuh
 $*h_1$ = { Enthalpy or } - entering air Btu/lb.
 $*h_2$ = { total heat of } - lvg. air Btu/lb. dry air
 T_1 = Temperature of entering air °F.D.B.
 T_2 = Temperature of leaving air °F.D.B.
 t_1 = Indoor design temperature °F.D.B.
 t_2 = Outdoor design temperature °F.D.B.
 W_1 = { Grains of water } @ entering cond.
 W_2 = { per lb. of dry air } @ leaving cond.

* See Enthalpy of air (Total Heat Content of Air) Table for exact values.

SUGGESTED LIMITS FOR ROOM LOUDNESS

Sones	DBA	Areas
1.3 - 4	32 - 48	Private homes (rural and suburban)
1.7 - 5	36 - 51	Conference rooms
2 - 6	38 - 54	Hotel rooms, libraries, movie theaters, executive offices
2.5 - 8	41 - 58	Schools and classrooms, hospital wards, and operating rooms
3 - 9	44 - 60	Court rooms, museums, apartments, private homes (urban)
4 - 12	48 - 64	Restaurants, lobbies, general open offices, banks
5 - 15	51 - 67	Corridors and halls, cocktail lounges, washrooms and toilets
7 - 21	56 - 72	Hotel kitchens and laundries, supermarkets
12 - 36	64 - 80	Light machinery, assembly lines
15 - 50	67 - 84	Machine shops
25 - 60	74 - 87	Heavy machinery

From AMCA Publication 302 (Application of Sone Ratings for Non Ducted Air Moving Devices with Room-Sone-dBA correlations).

SUGGESTED AIR CHANGES FOR PROPER VENTILATION

$$CFM = \frac{\text{Room Volume}}{\text{min/chg}}$$

Room Volume = L x W x H (of room)

Min/Chg	Areas
3 - 10	Assembly Hall
2 - 4	Attic
3 - 10	Auditorium
2 - 3	Bakery
2 - 4	Bar
12 - 18	Barn
1 - 3	Boiler Room
3 - 7	Bowling Alley
3 - 5	Cafeteria
4 - 10	Church
4 - 6	Classroom
3 - 7	Club Room
3 - 7	Dance Hall
4 - 8	Dining Room
2 - 5	Dry Cleaner
1 - 3	Engine Room
2 - 7	Factory
1 - 5	Foundry
2 - 10	Garage
2 - 5	Generator Room
3 - 8	Gymnasium
1 - 5	Kitchen
2 - 5	Laboratory
2 - 4	Laundry
3 - 6	Machine Shop
3 - 8	Mill
2 - 8	Office
2 - 5	Packing House
1 - 2	Projection Room
2 - 8	Recreation Room
2 - 6	Residence
5 - 10	Restaurant
5	Rest Room
3 - 7	Store
1 - 5	Transfer Room
3 - 10	Warehouse

DERIVATIONS OF AIR CONSTANTS

Air constants below apply to Std. Dry Air at 70°F and 14.7 P.S.I.A. (29.92 in. mercury column). They may be used in most cooling calculations unless extremely precise results are desired.

4.5 (to convert CFM to lbs./hr.)

$$4.5 = \frac{60 \text{ Min./hr.}}{13.33} \text{ or } 60 \times .075$$

where 13.33 is the specific volume of std. air (cu. ft./lb.) and .075 = density (lbs./cu. ft.)

$$1.08 = \frac{.24 \times 60}{13.33} \text{ or } .24 \times 4.5$$

.24 Btu = specific heat of std. air (BTU/LB/°F)

$$.68 = \frac{60}{13.33} \times \frac{1060}{7000} \text{ or } 4.5 \times \frac{1060}{7000}$$

Where: 1060 = Avg. Latent Heat of water vapor (BTU/LB)
7000 = Grains per lb.

RECOMMENDED AND MAXIMUM DUCT VELOCITIES

(MAXIMUM VELOCITIES SHOWN IN PARENTHESES)

DESIGNATION	RESIDENCES			SCHOOLS, THEATERS, PUBLIC BUILDINGS		INDUSTRIAL BUILDINGS	
	250	300	350	350	350	350	350
THESE VELOCITIES ARE FOR TOTAL FACE AREA							
Filters	(300)	300	(350)	350	(350)	350	(350)
Heating Coils	(500)	500	(700)	600	(700)	600	(700)
Cooling Coils	(450)	500	(600)	600	(600)	600	(600)
Air Washers	(500)	500	(500)	500	(500)	500	(500)
THE FOLLOWING VELOCITIES ARE FOR NET FREE AREA							
Fan Outlets	1000-1600	(1700)	1300-2000	(1500-2200)	1600-2400	(1700-2800)	
Main Ducts	700-900	(800-1200)	1000-1300	(1100-1600)	1200-1800	(1300-2200)	
Branch Ducts	600	(700-1000)	600-900	(800-1300)	800-1000	(1000-1800)	
Branch Risers	500	(650-800)	600-700	(800-1200)	800	(1000-1600)	

TERMS AND CONDITIONS



Our Terms and Conditions of Sale at the time of shipment shall exclusively apply to all sales of products as displayed on our webpage at <http://www.mingledorffs.com/terms-and-conditions>. At the time of this catalogs publication, the Terms and Conditions of Sale as published on our website are as follows:

1. GENERAL.

These Terms and Conditions of Sale (these "Terms") govern Customer's purchase of any heating, ventilation, air conditioning and plumbing equipment and related parts and materials and any ancillary services (the "Goods") from Mingledorff's, Inc. and its subsidiary George Holden & Associates, Inc. (collectively and each a "Seller"). If these Terms are first tendered to Customer before Customer tenders a purchase order or similar document to Seller, these Terms are in lieu of any terms later submitted by Customer and Seller rejects all additional or different terms and conditions of Customer, whether confirmatory or otherwise. If Seller tenders these terms after the tender by Customer of other terms, whether as part of a purchase order or otherwise, then Seller's acceptance of any offer by Customer associated with Customer's terms is expressly conditioned upon Customer's acceptance of these Terms exclusively and to the exclusion of any proffered Customer terms or conditions, regardless of whether these Terms contain any terms additional to, or different from, any terms proffered by Customer. Customer's performance, or acceptance of, or payment for, any products from Seller will constitute Customer's acceptance of these Terms exclusively. If there is proposal, quotation or an executed written sales agreement in effect between the parties (each a "Sales Agreement"), these Terms form a part thereof. Waiver by Seller of any breach, remedy or provision of these Terms shall not be construed to be a waiver of any succeeding breach or any other provision or legal remedy of Seller.

2. PRICE AND PAYMENT.

Orders are not binding upon Seller until accepted by Seller in its sole discretion. No order shall be deemed accepted by Seller unless and until either confirmed in writing by Seller or by delivery of the Good specified in the order, and then only on these Terms. Unless otherwise agreed to in writing by both parties, all accepted orders of the Goods will be invoiced at Seller's prices in effect on the date of shipment, which prices are subject to change from time to time. Customer may not withhold payment of any amounts due and payable as a set-off of any claim or dispute with Seller, regardless of whether relating to Seller's breach, bankruptcy or otherwise. Credit is extended at the sole discretion of Seller. Any discounts given to Customer by Seller in relation to the price of the Goods are conditional upon payment for the Goods being made strictly in accordance with the Sales Agreement and these Terms and to Customer's entire account for all products purchased from Seller being current. Unless otherwise agreed to by Seller in writing, Customer agrees to pay all amounts due to Seller within thirty (30) days from the date of invoice. Customer shall pay interest and service charges on overdue invoices from the due date until paid at a rate of 1.5% per month or the maximum legal rate, whichever is less, and any collection costs of Seller, including court costs and reasonable attorney fees. **NON-PAYMENT VOIDS ANY WARRANTY.**

3. FINANCIAL RESPONSIBILITY OF CUSTOMER.

Customer's solvency is a condition of Seller's performance and Seller may, at any time, in its sole discretion for credit reasons (including a good faith belief that a current or future payment is or may be impaired) or because of Customer's breach of this or any other agreement with Seller, suspend or change credit terms, fix a limit on credit, require progress payments, demand payment in full of any outstanding balance, accelerate all unpaid amounts owed by Customer, withhold shipments, demand COD or request other assurances of payment, cancel or terminate any order or agreement, or repossess all Goods previously delivered, which Goods shall become the absolute property of Seller subject to credit therefore. Customer grants to Seller a security interest in Goods delivered hereunder to secure Customer's obligations under these Terms and any Sales Agreement and grants to Seller the right to execute, deliver, and/or file any financing statement or do any other thing reasonably necessary to perfect Seller's security interest. Notwithstanding any other provision of these Terms, Seller reserves the right in its absolute discretion from time to time to require payment in full of the price of the Goods before delivery of all or any of the Goods. Seller may terminate any order or Sales Agreement by written notice to Customer if (i) a receiver or trustee is appointed for any of Customer's property; (ii) Customer is adjudicated or voluntarily becomes bankrupt or a debtor under any bankruptcy, dissolution or reorganization laws or similar law; (iii) Customer becomes insolvent or makes an assignment for the benefit of creditors; (iv) an execution is issued pursuant to a judgment rendered against Customer; or (v) Customer is unable or refuses to make payment to Seller. If any order or Sales Agreement is terminated by Seller pursuant to this section, Seller shall be relieved of any further obligation to Customer and Customer shall reimburse Seller for its termination costs and expenses and a reasonable allowance for profit.

TERMS AND CONDITIONS

4. DELIVERY.

Title to and risk of loss of the Goods shall pass to Customer upon tender of such Goods to Customer at Seller's designated facility. Unless otherwise agreed by Seller in writing, shipping terms shall be FOB, Seller's designated facility – freight prepaid and allowed to the first destination in the continental USA. Any shipping date provided by Seller is the Seller's best estimate and will not operate to bind Seller to ship or make deliveries on such date. If Customer fails to accept delivery of any Good delivered timely then Customer shall be liable for all costs and expenses arising out of such failure, including a reasonable storage fee. Customer must thoroughly inspect the Goods at the time of receipt for signs of damage, discrepancies or a shortage. Inspections of the Goods at the time of delivery shall be commenced in the presence of the carrier's driver and Customer shall note on the freight bill any shortages, discrepancies or damages of any Good received on the carrier's receipt. If concealed loss or damage is discovered, Customer must report it to the carrier within 15 days from the date of receipt. Claims for Goods damaged during shipment shall be made by Customer to the carrier and are not covered under the warranty provisions stated herein.

5. CANCELLATION. CHANGES AND RETURNS.

Orders are not subject to cancellation, change or return unless agreed to in writing by an authorized representative of Seller. Seller's consent may be subject to, in Seller's sole discretion, a revision in prices and/or delivery dates and Customer's payment of any costs and expenses incurred by Seller (including stocking and transportation fees) resulting from such approved cancellation, change or return. Customer shall only receive credit for approved returns and the material must be standard stock and in good condition. Such credit shall be the invoice price less a restocking fee on acceptable goods, and less all shipping and handling charges.

6. PERFORMANCE AND EXCUSABLE DELAY.

Company shall be obligated to furnish only the Goods described in the Sales Agreement and in submittal data (if such data is issued in connection with the order). Acceptance of the Sales Agreement or the submittal data shall be deemed as acceptance of the suitability of the Goods for the particular project or location. Unless specifically stated in the Sales Agreement, compliance with any local building codes or other laws or regulations relating to specifications or the location, use, installation or operation of the Goods is the sole responsibility of Customer. Customer agrees to use and install all equipment in accordance with all local, state and federal requirements, including without limitation, all applicable Regional Efficiency Standards. Seller shall not be liable for any expense, loss or damage resulting from delay in delivery or prevention of performance caused by fires, floods, acts of God, strikes, labor disputes, labor shortages, lack of or inability to obtain materials, delays of manufacturers or vendors, fuels, supplies or equipment, riots, accidents, transportation delays, acts or failures to act of any government or of Customer, or any other cause whatsoever, provided that such cause is beyond the reasonable control of Seller; and Seller shall have such additional time for performance as may be reasonably necessary under the circumstances and may adjust the price to reflect increases occasioned by such delay.

7. DEFERRED DELIVERY.

Seller shall be entitled to an adjustment in price commensurate with any increase in the cost of production and any other losses and expenses incurred by Seller attributable to delays due to Customer, including its delay in approving the submittals. Any deferred delivery request by Customer shall be subject to Seller's written approval. If such approval is given, Seller shall have the right to charge Customer for the completed portion of the order and to warehouse all completed Goods at Customer's expense and risk of loss. Seller also reserves the right, at its option, to cancel said uncompleted portion in accordance with Section 6 above, or to revise its prices and delivery schedules on the portion not completed to reflect its increased costs and expenses attributable to the delay.

8. LIMITED WARRANTY AND DISCLAIMERS.

Customer acknowledges that Seller is the distributor, not the manufacturer, of the Goods and as such, Seller makes no warranties with respect to the Goods whatsoever. Seller will provide Customer the express limited warranty provided by each manufacturer, if any, of the Goods. Customer agrees to cooperate with Seller in processing all warranty claims for Goods with the manufacturer. Any claims relating to the Goods shall be deemed waived by Customer unless submitted to Seller in writing within ten (10) days from the date Customer discovered, or should have discovered, the issue. Customer acknowledges that manufacturers' warranties typically contain sole and exclusive remedies limited to the replacement of nonconforming parts or refund of the purchase price paid for the non-conforming Good. No warranty shall apply to any Good that was altered

TERMS AND CONDITIONS



or was otherwise subject to abuse, neglect or improper use by Customer or improper storage, maintenance or application. EXCEPT FOR THE SPECIFIC WARRANTIES SET FORTH IN THIS SECTION, SELLER MAKES NO OTHER WARRANTIES WHATSOEVER, EXPRESS OR IMPLIED, REGARDING THE GOODS, WORK, SERVICES OR PERFORMANCE OF ITS OBLIGATIONS HEREUNDER, AND SPECIFICALLY DISCLAIMS ANY WARRANTIES OF MERCHANTABILITY OR FITNESS FOR A PARTICULAR PURPOSE.

9. LIMITATION OF LIABILITY.

IN NO EVENT SHALL SELLER BE LIABLE TO CUSTOMER OR ITS CUSTOMERS FOR ANY PUNITIVE, SPECIAL, INCIDENTAL, INDIRECT OR CONSEQUENTIAL DAMAGES INCLUDING, BUT NOT LIMITED TO, LOSS OF DIRECT OR INDIRECT PROFITS, REVENUE, USE, OR BACK CHARGES, WHETHER ARISING IN CONTRACT, TORT, OR OTHERWISE, EVEN IF CUSTOMER OR ANY OTHER PARTY HAS BEEN ADVISED OF THE POSSIBILITY OF SUCH DAMAGES. IN NO EVENT WILL SELLER'S AGGREGATE LIABILITY TO CUSTOMER EXCEED ALL AMOUNTS ACTUALLY PAID BY CUSTOMER TO SELLER. SELLER SHALL NOT BE LIABLE FOR AND CUSTOMER AGREES TO INDEMNIFY SELLER FOR ALL PERSONAL INJURY, PROPERTY DAMAGE OR OTHER LIABILITY RESULTING IN WHOLE OR IN PART FROM THE NEGLIGENCE OR WILLFUL MISCONDUCT OF CUSTOMER. In no event shall Seller be liable or responsible for the actions or omissions of Customer, its other contractors or third parties outside of Seller's control. It is the sole and exclusive responsibility for the Customer or its designee to verify and approve the submittals for the project.

10. CONTROLLING LAW.

These Terms and all accepted orders shall be construed in accordance with the laws of the State of Georgia, without regard to its conflict of law principles. Customer agrees that any and all disputes with Seller, including contract and tort claims, shall be resolved in the state and federal courts situated in Georgia, and that these courts shall have the exclusive jurisdiction over all such disputes and Customer consents to the personal jurisdiction in these courts. Any action brought by Customer against Seller shall be within one (1) year after the cause of action arises or it shall be deemed forever waived.

11. TAXES.

Seller's prices do not include sales, use, excise or other similar taxes (unless expressly stated or itemized by Seller in writing as part of Seller's prices). Consequently, in addition to the price specified herein, the amount of any present or future such tax shall be paid by Customer, or in lieu thereof, Customer shall provide Seller with all tax-exemption certificates required by the taxing authorities, at the time of sale.

12. CONFIDENTIALITY.

Customer will not disclose to third persons any proprietary or confidential information of Seller concerning its business and operations, including without limitation, pricing information, for a period of five (5) years from the date such confidential information was learned or for confidential information meeting the definition of "trade secret" under applicable law, until such information is no longer a "trade secret." The obligations of confidentiality in this Section 12 do not apply to Confidential Information to the extent that the Confidential Information becomes readily ascertainable by proper means by the public other than through breach of this Section 12 by Customer.

13. ADDITIONAL TERMS.

The provisions of these Terms and the Sales Agreement, if any, constitute the entire agreement between Customer and Seller with respect to the matter contained herein and supersedes any prior oral or written communications, understanding, representations, proposals or agreements with respect to such subject matter. Seller may revise these Terms from time to time. These Terms may not be amended or modified by the Customer except upon the execution of a written agreement signed by both parties indicating an intent to modify these Terms. Customer may not assign any of its rights or obligations hereunder or under any order. If any provision deemed severed from these Terms and/or the Sale Agreement and the validity of the remainder of these Terms and/or the Sale Agreement shall not be affected thereby. The provisions of these Terms that by their nature are reasonably intended by the parties to survive the expiration or termination of the Terms or any accepted order, shall survive the expiration or termination of the Terms or any accepted order.

OUR LOCATIONS

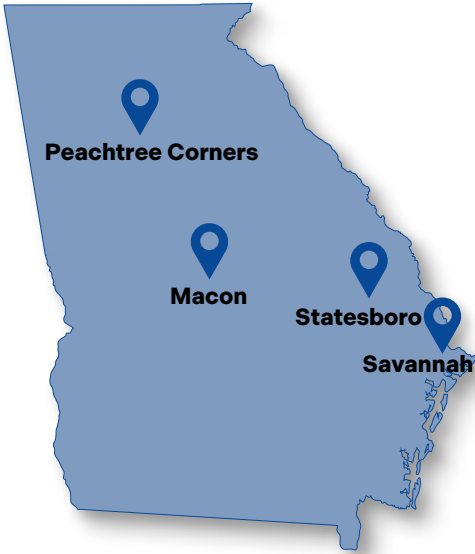

Peachtree Corners (Stocking Warehouse)

3350 Green Pointe Pkwy, Suite 100
Peachtree Corners, GA 30092
(770) 458-4000

Macon

1943 North Jefferson St NE , Suite B4
Milledgeville, GA 31061
(770) 670-2731

Savannah

100 Riverview Drive, Suite 305
Savannah, GA 31404
(912) 944-3917

Statesboro

124 Savannah Avenue, Suite B
Statesboro, GA 30458
(706) 854-0738





TRAINING CENTER

A CORPORATE OFFICE
TRAINING CENTER
IN THE SCIENCE & BIOPHARMA
HOLDEN & ASSOCIATES

